

E. INVESTIGATION IMPLEMENTATION

OCAM's innovative science investigation requires an equally strong implementation plan optimized SOFIA platform. The approach outlined here is based on proven laboratory work combined with the technological and managerial heritage of both ground-based and balloon-borne programs. While characterized as a Technology Demonstration proposal, this implementation goes much further; it provides an extensible platform of a closed-cycle cryostat, power systems, modular IF processors, digital spectrometers, command/control systems, and data management that all can be readily extended to a larger focal plane array with only incremental changes. OCAM and/or its focal plane upgrade could potentially serve as an exciting future facility instrument for SOFIA.

E-1 Mission Design

OCAM's natural flow of requirements from science goals to instrument implementation (Science Foldout) allows for the design of a 3-flight design reference mission that addresses conclusively the science questions and goals of Section D. To maximize the opportunity to schedule the instrument on SOFIA, the OCAM Science Team has selected a master list of astronomical targets (Table E-1.1) which provide the basis for the design reference mission. While there are many suitable massive star forming regions along the Galactic Plane and several nearby galaxies of special interest for [OI] mapping, there is only one Galactic Center – whose observations are central to the scientific objectives of this project. Therefore, the desired 3-flight demonstration program is requested when the Galactic Center is observable, from mid-April through September. Using SOFIA flight planning tools, two sample missions spanning this observing window are shown in Tables E-1.2 and E-1.3. These missions are launched from

SOFIA's home base in Palmdale, California and maximize the flight duration using a stepped flight profile whose altitude increases throughout the flight, from 37,000 to 43,000 feet MSL as the onboard fuel load decreases. Contiguous flight legs per source are typically 2-3 hours. Coupling instrument sensitivity with atmospheric transmission, the delivered mapping speeds would be >100 square arc-minutes per 3 hour flight leg to a sensitivity of 1.8×10^{-4} erg/s/cm²/sr. While it is anticipated that a technology demonstration program is best supported from Palmdale, the prospect of southern hemisphere SOFIA missions is advantageous for sources like the Galactic Center and could be explored for possible follow-on flights with OCAM.

Object	Science Goal #	Type	Month(s)
M82	4	Starburst galaxy	May
NGC 4038/9	4	Merging galaxies	Jan-July
M83	4	Sc galaxy	Jan-July
VLA 1623	2	SFR	Mar-Sept
Galactic Center	3	Gal. nucleus	April-Sept
M16	1	SFR	April-Sept
M17	1	SFR	April-Sept
W43	1,2	SFR	April-Sept
W49	1,2	SNR	April-Sept
W51	1,2	SFR	April-Oct
NGC 7027	1	PN	May-Sept
Cepheus A	1,2	SFR	June-Sept
M31	4	Sb galaxy	July-Sept
M33	4	Sc galaxy	July-Sept
W3	1,2	SFR	Aug-Sept
M42	1,2	SFR	Sept
NGC 7023	1	EN	Sept

Table E-1.1: Master target sample for the OCAM science demonstration flights. From the April to September time period, an outstanding sample of sources can be selected to span the 3 targeted

flights. Abbreviations: SFR=star formation region, SNR=supernova remnant, EN=emission line nebula, PN=planetary nebula. Science goals are defined in Section D-0.1.

Time (UT 5/1)	Altitude (kft)	Source	AZ range EL range
03-07	37	M82	90-60 45-50
07-09	40	NGC 4038/9	225-270 20-30
09-10	40	VLA 1623	270 30
10-13	42	Gal. Center	240-290 20-30

Table E-1.1: Sample flight plan for an OCAM flight in early May

Time (UT 9/15)	Altitude (kft)	Source	AZ range EL range
02-05	38	Gal. Center	240-290 20-30
05-08	39	M33	150-170 20-60
08-09	41	NGC 7027	30 45-60
09-10	43	Taurus	140-180 40-50
10-13	42	Orion (M42)	180-225 20-45

Table E-1.2: Sample flight plan for an OCAM flight in mid September.

E-2 Instrument Requirements & Constraints

E-2.1.1 Optical (Chris W.) – 1 page

E-2.1.2 Mechanical

The OCAM mechanical interface to the SOFIA observatory has been chosen to be as simple as possible, leveraging the maximum amount of existing hardware and proven configurations. The OCAM cryostat attaches directly to the SOFIA Instrument Mounting Flange (IMF) directly, forming the pressure bulkhead to the ambient atmosphere. All optics, including calibration loads, are inside the cryostat vacuum vessel, so no additional mechanical interfaces are present within the IMF. The cryostat is relatively compact and light. As shown in the Instrument Foldout, Figures 2.2 and 2.3, the OCAM cryostat fits easily within the dynamic SI envelope, with large clearance margin. The static and installation envelopes are similarly accommodating. All instrument electronics are housed in the Counter Weight Rack (CWR) mounted on the TA Counterweight Plate. OCAM electronics will fill approximately half the available space in the CWR, allowing for straightforward re-configuration to meet center of gravity restrictions.

The OCAM closed-cycle cryogenic system requires connection between the compressor system, mounted at the PI rack locations. The compressed helium lines consist of two ½” braided stainless steel jacketed line, ~25m in length with an outer diameter of ~1”. These lines will be routed through the Cable Load Alleviator Device (CLAD) Right Hand Cable Bundle in the outer bundle, where sufficient space is available for the lines. These lines have Aeroquip self-sealing pressure couplings on each end. A bulkhead fitting will be mounted at the TA patch panel for connection to a shorter set of similar line supplying the cold head on the cryostat. No other custom installation is needed in the CLAD.

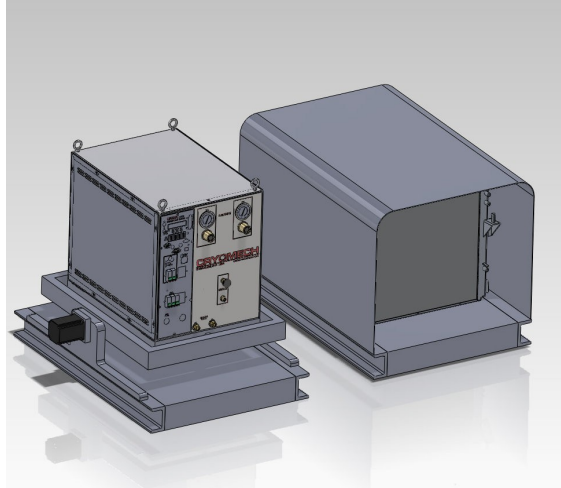

Figure E-2.1: The OCAM cryogenic compressor system. The water cooled compressor and stabilization gimbal are mounted on one PI pallet, with the water-air heat exchanger system on another.

The cryogenic system requires a compressor system to supply compressed helium gas to the cold head, and to dump waste heat from the return gas. OCAM will use a commercially available compressor from Cryomech Inc., modified and tested by Cryomech to meet airworthiness requirements. This compressor is water cooled, so it will be combined with a Cryomech supplied circulator pump and water-air heat exchanger to dump the system waste heat (~ 8 kW) to the cabin air. The compressor will be mounted on a powered tip-tilt stage with tilt sensors that will maintain the oil-sealed compressor at a level attitude $\pm 5^\circ$. A motor control system will be implemented in Labview to control this stage. The tip-tilt stage and other compressor mounting hardware will be engineered by Universal Cryogenics and the University of Arizona, and fabricated by Universal Cryogenics. The compressor and tip-tilt stage will mount on a modified version of the PI equipment rack: a flat pallet interface to the existing L3 support pallet. This platform will be designed and qualified in consultation with NASA. A second identical pallet will be used to mount the circulator pump and heat exchanger used to transfer heat from the compressor cooling fluid to the cabin air. A CAD model of the pro-

posed configuration is shown in Figure E-2.1. Table 2.0 shows the current best estimates for OCAM instrument mass and mass margin, organized by mounting location. The OCAM system has large mass margins for all mounting locations.

E-2.1.3 Pressure

The OCAM pressure bulkhead is formed by the cryostat at the outer IMF location. No optical window will be used. This bulkhead will be formed by the cryostat front plate, in a manner similar to the current generation FORCAST instrument. The cryostat pressure vessel and bulkhead will be engineered using a combination of FEA tools and hydrostatic test verification to assure it meets necessary airworthiness requirements. Since there are no liquid cryogenics in OCAM, the mechanical requirements for guard vacuum failure are greatly reduced. With the OCAM closed cycle system, even a catastrophic loss in guard vacuum will result in helium gas pressures no greater than that of the powered-off system at room temperature. The closed cycle cryogenic system (including the cold head, pressurized helium flex lines and compressor) will be engineered and tested by Cryomech Inc. to meet all necessary requirements documented in the SOFIA Science Instrument System Specification document for pressurized systems. Cryomech will modify their standard systems as needed to meet all airworthiness requirements.

E-2.1.4 Electrical

The OCAM system has been designed to maximize simplicity when interfacing electrically to the SOFIA observatory. OCAM uses a distributed computing model, with small, single board computers each controlling OCAM subsystems, connected via Ethernet. The backend spectrometer for OCAM is co-located with the instrument in the CWR, so no analog science signals are routed through observatory wiring. The hardware in the CWR will inter-

face with the TA patch panel only via 115VAC power, chopper control, cold head drive and Ethernet. The cold head drive signals will use existing wiring in the PI patch panel (J75 - J79). 1000 BASE-FX to 1000 BASE-T media converters will be used in the CWR and the PI instrument rack to convert to copper wire Ethernet for the SI instrument network. Timing will be obtained from the MCCS LAN via NTP for time synchronization of the OCAM computers. The compressor system will interface to the PI Patch Panel via the 20 kVA power system connectors. There is no ICD for this new power system, so the OCAM team will work with NASA to design this interface.

E-2.1.5 Power

The OCAM power budget is dominated by the ~10 kVA (CBE) of power necessary to operate the compressor, circulator pump and heat exchanger fan for the cryogenic system. This power will be provided by the new 20 kVA power system upgrade for the SOFIA observatory. The compressor system can be operated from 220/230 VAC 3ph 60 Hz, 460 VAC 3ph 60 Hz, 200/220 VAC 50 Hz or 380/420 VAC 3ph 50 Hz power sources as standard, but custom configurations are possible to maintain compatibility with the new SOFIA power system.

Power for the rest of the instrument is modest. The current best estimate for power consumption of the remainder of the OCAM instrument is ~520W, provided by the existing 2 kVA UPS power system. This results in almost a factor of 4 margin on power for that subsystem.

E. 2.1.6 Software

E-2.1.6.1 Mission Command and Control

To interface the OCAM instrument to the SOFIA standard Mission Command and Control System (MCCS), the science instrument rack will contain a computer with a dedicated instrument command and control system (C&C). The C&C computer will consist of a

ruggedized Parvus single board computer, redundant industrial SLC solid state disks from PSI, and a MESA 4I71S ethernet switch. The systems are fault-tolerant, conduction cooled, and rated for operation over -40 C to +85 C. The solid state discs are redundant and the system is designed to boot off of the alternate disk whenever it boots without having been shutdown properly. The software interface of the C&C computer to the MCCS will comply with the relevant interface control document (SOF-DA-ICD-SE03-052). The science team has extensive experience producing software for C&C systems on long duration balloon missions and ground based telescopes and will lead the development of the needed software pursuant to the required interfaces. Extensive testing will also be undertaken by members of the OCAM team using the Systems Integration Laboratory to ensure compliance with these interfaces well before the instrument is prepared for its pre-ship review. Similarly the OCAM team will prepare and provide functional specifications and testing plans for all C&C software to confirm that any hazardous elements have hardware mitigations in place to protect from any possible software malfunction.

E-2.1.6.2 Data Cycle System

The C&C computer will also interface with the SOFIA standard data cycle system (DCS) as per the relevant interface control document (SCI-US-ICD-SE03-2023). While the DCS will be utilized to provide on-aircraft data archiving, for redundancy purposes the C&C will also be used to store raw and reduced data.

E-2.1.6.3 Data Reduction Pipeline

While not generally required for a technology demonstration proposal, the team believes it is best practice to conform to the standards required for data reduction pipelines for longer duration SOFIA instrument projects, as detailed in the interface control documents and

the general SOFIA data processing plan (SCI-US-PLA-PM17-2010). However, while the pipeline will be provided to the SMO for archival purposes, there is no expectation from the instrument team of any additional support, and the OCAM team will take full responsibility for all aspects of data reduction as is expected for a technology demonstration project. The OCAM supplied pipeline will build upon a pipeline developed by members of the science team for automated on-board reduction of long duration balloon missions. This pipeline begins by taking the raw numbers produced by the spectrometers and immediately formatting each spectrum as a FITS file tagged with housekeeping, position, and calibration data stored directly with the spectrum in the form of FITS headers. These raw FITS files are then stored and passed along to the calibration phase of the pipeline, which uses calibration load data and reference information to produce a calibrated spectrum, which is similarly stored for future reference. Finally calibrated spectra are re-gridded using an optimized On-the-Fly reduction scheme and collectively stored as a single large data cube for a given target upon the completion on observations. These data cubes represent the final product of the pipeline and can be formatted into figures for publication using a wide range of commonly available visualization tools.

E-2.2 Ground Support Equipment

OCAM will require a small suite of ground support equipment for testing and verification before flights. A second cryogenic compressor system will be purchased and installed in the PIF laboratory to allow ground testing of the instrument independent of the flight cryogenic compressor. This will be a standard Cryomech water cooled compressor functionally identical to the flight unit, but available off-the-shelf. A GSE equipment rack will hold all OCAM electronics normally mounted in the CWP rack. Duplicate cable harnesses and cryogenic flex lines will be constructed for testing.

OCAM will use the Telescope Assembly Alignment Simulator (TAAS) to map the location of the 16 beams relative to the telescope boresight. This will set focus and also provide the de-rotation parameters for reconstruction of pixel positions during OTF observations. The instrument IF processors will provide integrated total power measurement across the band, in addition to data from the spectrometer system. OCAM GSE software will use the chopper signal and the total power data from the IF system and spectrometers for lock-in detection during the beam mapping and focus measurements.

Because the OCAM cryostat is very compact and light relative to other SOFIA instruments, the SI Handling Cart's design is simplified. OCAM on the handling cart will meet dimensional and mass requirements for handling operations with large margins. A simple 4 wheel push-cart will be designed and constructed by Universal Cryogenics, the contractor for the EXES handling cart. Locking, large diameter wheels will be used to ensure low wheel pressure and ability to travel over rough surfaces. The cart will be designed to be forklift and lift-gate compatible. The instrument will be raised and lowered on a scissor-jack mechanism. We will explore the use of high-load commercial laboratory lab jack mechanisms for this purpose (i.e. the Newport Model 281 300 lb. lab jack). If no commercial jack meets SOFIA requirements, we will engineer and construct our own jack to meet the 2" vertical travel requirement. The instrument and jack will be mounted on the front of the handling cart, with counterweights installed on the cart to ensure a safe center of gravity. This will allow simple and straightforward instrument mounting to the TA flange, meeting all requirements described in SIC_AS_01.

E-3 Airworthiness

Airworthiness analysis and testing responsibilities will be managed by the University of Arizona and carried out by the University of Ari-

zona and contractors Universal Cryogenics and Cryomech Inc. Mechanical analysis will be performed on all critical OCAM components to meet the requirements set forth in the SOFIA Science Instrument System Specification document. All materials and fasteners will be procured to meet mechanical and traceability requirements. The cryostat and electronics configuration is simple and is similar in layout to existing hardware (i.e. FORCAST). OCAM will use a new, closed cycle cryogenic system that requires the mounting of a compressor on a tip-tilt stage. The mechanical design of this system and its interface to the SOFIA aircraft via custom pallets mounted at the PI equipment rack locations will be done by University of Arizona mechanical engineers and Universal Cryogenics. They will work with SOFIA observatory staff to ensure that the new pallet and compressor tip tilt stage meet all airworthiness requirements.

Pressure testing for the closed cycle cryogenic system will be carried out by Cryomech Inc. before delivery to the OCAM team. Cryomech believes that their systems will meet all pressure test requirements as-is, but will modify them as needed to meet requirements. The cryostat vacuum vessel and cryostat window will be designed by Universal Cryogenics using FEA tools, then tested via hydrostatic testing.

OCAM electrical systems will use aircraft approved wiring and connectors for all electrical connections. COTS aircraft grade cabling will be used where possible, with custom-fabricated cable harnesses implemented when no commercial product is available.

The instrument handling cart will be designed and constructed by Universal Cryogenics, who is currently producing the EXES instrument handling cart. This handling system will be analyzed via FEA tools by Universal Cryogenics and the University of Arizona to assure it meets all observatory requirements.

All airworthiness activities will be planned, overseen and verified by outside con-

sultant **Foo Bar (Hop's guy)**, who has extensive experience in airworthiness certification for industry, defense and scientific applications in the aerospace field. He will work with the University of Arizona, OCAM contractors and NASA to produce an airworthiness certification plan for all components of the OCAM system. He will then work with the University of Arizona to ensure that the plan is executed and all testing and documentation implemented to meet all observatory requirements.

E-4 Data & Observing Requirements

E-4.1 Instrument Operations

[being added currently, look for v10]

E-4.2 Data Rights & Archiving

In addition to archiving the raw instrument data with the SOFIA Science Mission Operations Center (SMO), the OCAM team intends to exceed the expectations for a technology demonstration project by making the data reduction pipeline and reduced data products rapidly available to the public. The pipeline and reduced products will be delivered to the SMO and the public scientific community as soon as calibration and data formatting is complete, waiving the one year proprietary period. Even if calibration should take longer than anticipated, the data and pipeline will be released no later than one year following the flights, consistent with the standard one year restricted access period for the raw data itself.

E-5 Technology Development & New Technology (Chris W.)–

F- Management and Schedule

The management of the OCAM project builds on the successful UA Stratospheric TeraHertz Observatory (STO), the clear definition of mission objectives and requirements, and the heritage and maturity of the technical implementation.

F-1 Management approach.

The University of Arizona (UA), under the leadership of Principal Investigator (PI) Dr. Christopher Walker, has the overall responsibility for the performance, cost, and schedule of the OCAM Technology Demonstration Instrument. PI Walker directs the activities of the OCAM Science Team. Program Manager (PM) Mr. Brian Duffy (UA) reports to PI Walker. PM Duffy manages all aspects of the engineering and flight systems, monitors the schedule and costs, and oversees the contracting activities.

PM Duffy is supported by the UA OCAM project office comprised of a Deputy Project manager (Mr. S.H. Bailey with more than 20 years of spaceflight experience) and a Systems Engineering and Safety and Mission Assurance lead. Dr. Craig Kulesa leads the UA Instrument engineering team. PM Duffy lead Mission Operations. The organizational roles and responsibilities are shown above. This management structure builds on the previous successful collaboration on the STO project.

F-2 Development Plan.

OCAM science and measurement requirements and the flow down of these requirements are articulated in the proposal. Prior to the Preliminary Design Review OCAM creates the formal requirements for subsystems and prepares the interface control document between the Instrument and the SOFIA Telescope System culminating in a Systems Requirement Review (SRR) and Experiment Interface Review (EIR). SRR and EIR establish the basis for the detailed Phase B plan. During Phase B the development of the Instrument proceeds with weekly coordination meetings and telecons and the exchange of technical data through preliminary design and PDR and detailed design and CDR. Long lead items for the Instrument will be released to procurement

before CDR based on successful peer reviews and the consent of PI Walker and PM Duffy.

Spares shall be procured, tested, and placed in bonded stores to avoid delays. The formal identification and justification of spares will be completed during Phase B.

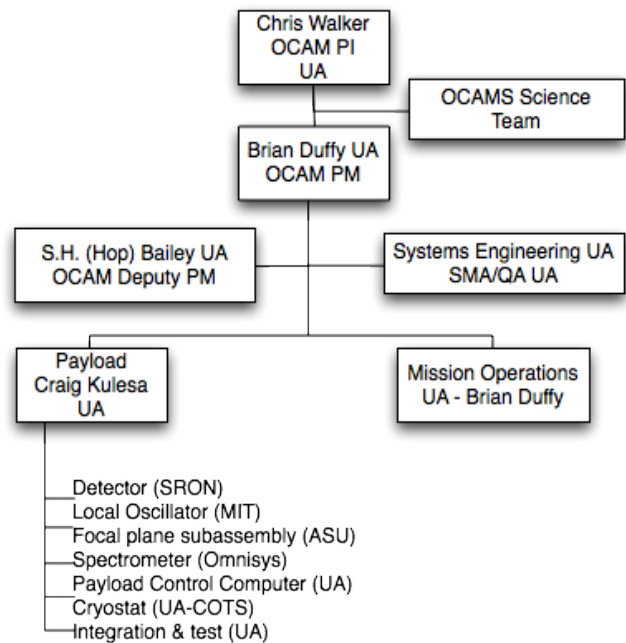

Figure F-1. OCAM Project Organization

Instrument components are integrated at the UA prior to test, acceptance, and delivery to SOFIA integration in Palmdale, CA. SRON and ASU deliver detector components and the focal plane subassembly to the UA for integration with the local oscillators provided by MIT. Omnisys delivers the spectrometer. UA integrates and tests the Instrument to acceptance. UA provides pre-SOFIA integration support and OCAM integration onto SOFIA in Palmdale. UA supports three test flights of the OCAM Instrument on SOFIA.

F-3 Systems engineering and safety and mission assurance (SMA).

UA has project-level responsibility for systems engineering and safety and mission assurance, establishing project-level requirements and policies. The UA establishes subor-

dinate requirements flow-down, test plans and procedures, and SMA policies using the best practices of the organization.

Risk factors rated “high” require new plans and processes, are actively managed, and, when required, are allocated reserves or mar-

Table F-1. *OCAM risks have been identified, mitigated, and included in the development of the project schedule and cost reserves. The mitigation includes the descope strategy.*

<i>Rank</i>	<i>Risk Concern</i>	<i>Mitigation and Descopes</i>	<i>Decision Point</i>	<i>Impact</i>
1	Local Oscillator (LO) output power at [CII] or [OI] initially not sufficient to drive 16 pixels	Use two separate LO units, each driving 8 pixels. Plan for an price a second LO delivery with 10x the required power	Phase C to release 2nd LO delivery	Impact: No cost impact, 2nd delivery in proposed budget.
2	Receiver sensitivity less than expected.	Factor of two less than target sensitivity can be accommodated without impacting minimum science mission.	Phase C	Reduces size of planned survey regions. No cost impact.

F-4 Risk management and risk mitigation.

OCAM relies on early identification and tracking throughout the project to manage and minimize risks. Mitigation planning requires consideration of alternative actions, personnel assignments, cost estimates for the alternatives, and a statement of work for the mitigation effort. OCAM incorporates a continuous process to research, accept, watch, and mitigate each risk. Mitigation plans are developed, implemented, and tracked as a function of risk priority and rating; they are required for all risks rated “significant” or higher. “Significant risks” are actively managed and, when required, reserves or margins are allocated at the discretion and approval of the OCAM PI to ensure HiSCI can complete the mitigation plan effort. The management and allocation of OCAM reserves requires continuously updating schedule and costs-to-date to project cost-to-complete. These data combined with the estimated cost of mitigating an identified risk will influence the mitigation strategy adopted.

gin. Risk mitigation progress is carefully tracked and documented. Detailed mitigation plans developed for significant risk items are regularly monitored so that any expenditure of cost or schedule reserves results in lowered risk exposure levels. The results of mitigation activities are achieved.

F-5 Acquisition strategy.

UA, Instrument component providers (JPL, MIT, CalTech, and SRON), and science team members submitted a joint proposal for OCAM with the UA as the PI organization. On this basis UA authorizes direct-funding by NASA to Sandia Labs (MIT’s OCAM partner) and establishes contracts with MIT, CalTech, SRON, and the science team organizations. For direct-funded organizations UA prepares a formal statement of work including technical, schedule, and cost reporting consistent with the overall project plan. All work is performed on a cost reimbursable or cost plus basis with a cost cap consistent with the submitted budgets. UA retains and controls the release of all reserves.

For other procurements each lead organization uses their established processes and procedures to solicit and award purchase orders or contracts consistent with their statement of work and UA-approved project plans.

F-6 Schedule.

The OCAM schedule is shown below. UA maintains the OCAM Integrated Master Schedule (IMS) using inputs and updates from team members.

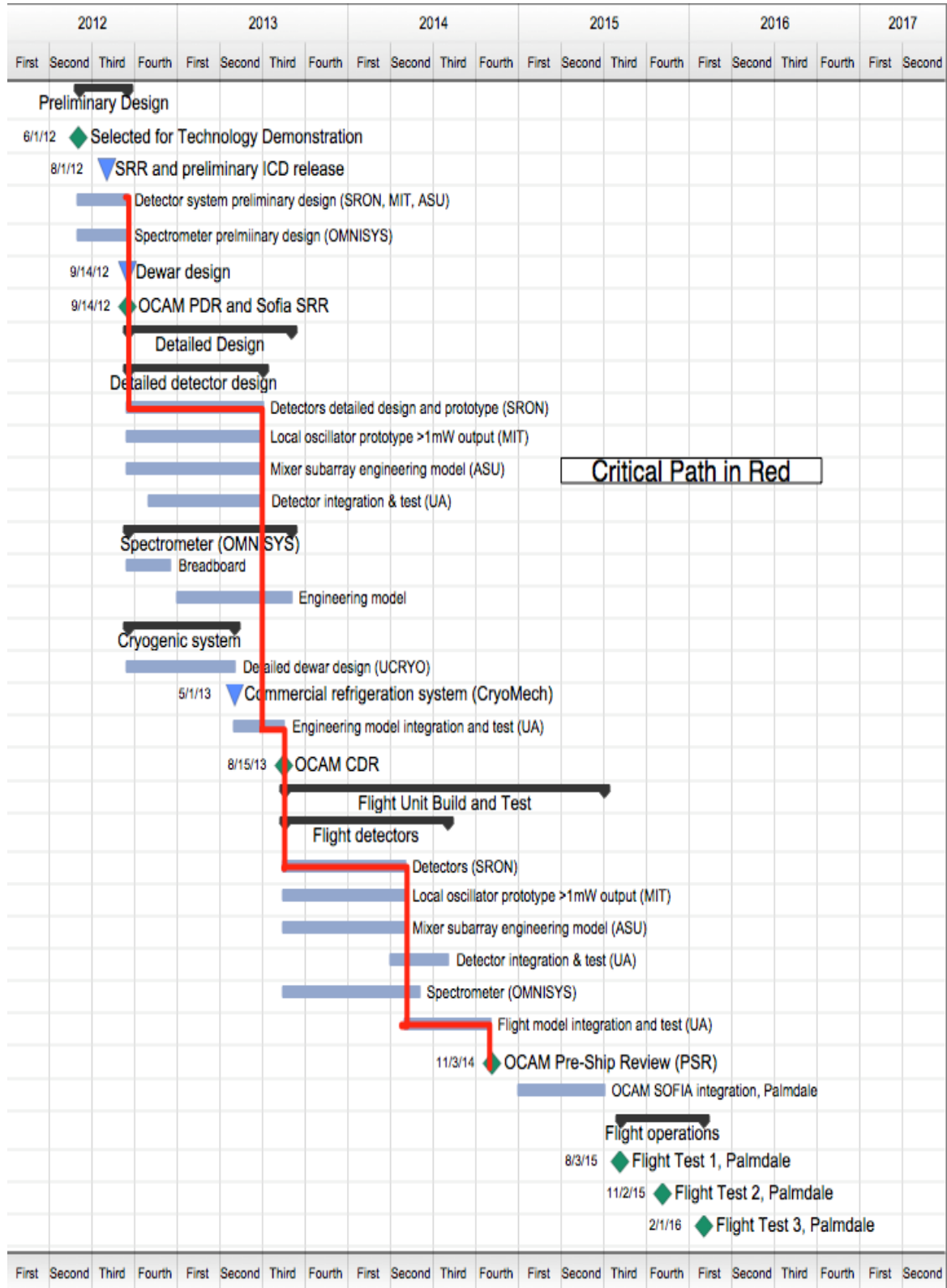

F-7 Decision making process

PI Walker is accountable to NASA for the success of the OCAM Technology Demonstration Instrument, and has full responsibility for its scientific integrity and mission execution within cost and schedule. Final decision authority for all matters impacting level one requirements and science, including descopes and reserves, rests with Dr. Walker. He delegates day-to-day development and operational decision-making authority to PM Duffy. All decisions affecting technical aspects of the OCAM imager are based on a fully integrated assessment of the science requirements, risk, performance, budget, schedule, and available reserves and margin. Final decisions will be comprehensive in nature, drawing information, analysis, and recommendations from the Science Team, project system engineer and engineering leads. Decisions that impact cost, schedule, or requirements are addressed via the Change Control Board (CCB) process, which is led by Dr. Walker.

F-7 Resource management strategies (schedule, cost, performance).

UA, working with Instrument component providers (JPL, MIT, SRON, Omnisys), establishes a baseline schedule, cost, and performance (based on the requirements review) prior to PDR. The baseline is updated at PDR to incorporate the preliminary technical data package including all drawings. Changes to the baseline require submission of an engineering change request supported by fully developed cost, schedule, and performance impact. The PI is the decision authority for changes to the baseline.

In addition to the formal change control process, UA conducts weekly telecoms or meetings with all participants to monitor progress and promote thorough and open communication. Working groups will be established for systems engineering, management, and specific design disciplines as required to facil-

itate complete face-to-face exchange of information.

The schedule is tracked weekly based on the telecoms and/or meetings and updated monthly. Costs are updated monthly consistent with the financial cycles of UA. A Monthly Management Review (MMR) assesses progress, identifies problems, and provides a basis for informed decision making, especially as it pertains to cost and schedule margins.

UA establishes a secure project electronic exchange and decision-making site used to control and document all decision making. All problem failure reports (PFRs), software trouble reports (STRs), and engineering change requests (ECRs) are reported into this system which includes information and flow control rules. Submission of a PFR, STR, or ECR triggers automatic email notification for disposition and decision-making. Decision-making requires archived electronic voting or direction. In addition, the system archives all documents associated with a report so that traceability is maintained to cost and schedule impact estimates, white papers, drawings, analysis, test results and all other information.

F-8 Export control

The UA develops a Technology Control Plan (TCP) during after award to ensure compliance with US Export Control Laws. The TCP identifies the participating OCAM personnel, facilities, and technology the requirements for control of defense articles and services, if any, on the OCAM project. After award the UA Export Control Officer, together with the OCAM PI and PM establishes a OCAM Export Control Declaration to determine if any technology element falls under the US Munitions List and is subject to Export Control restrictions. This Declaration serves as the basis for the submission of requests for Export Licenses or Technical Assistance Agreements, if any are required. Technology and articles that fall under the control of the Export Adminis-

tration Regulations (EAR) are identified using the Commerce Control List. See Appendix 5 for the Draft International Participation Plan.

F-9 Previous experience

The Steward Observatory Radio Observatory (SORAL), under the direction of Professor Chris Walker, has developed state of the art instrumentation for millimeter and submillimeter wavelengths. Current projects include the 64-element SuperCam receiver for the Heinrich Hertz Telescope, receivers for the AST/RO telescope and the South Pole, and the Stratospheric Terahertz Observatory (STO), a long duration submillimeter balloon Instrument. OCAM team members formed a central role in all of these prior projects. STO is the precursor mission to OCAM. The first engineering test flight of STO was from Ft. Sumner, NM on October 15, 2009. The ~30 day science flight is scheduled for December 2011.

G- Cost & Cost Estimating Methodology

The OCAM Project cost is summarized in the table below. See Cost Table B-3 and the detailed budgets for details.

The OCAM Project budget was developed with signed-off inputs from each participating

Participating Organizations		
Organization	Role	Basis of Estimate Funding
SRON (Netherlands)	Detector fabrication	Signed-off cost; Cost plus fixed fee, capped
MIT	Detector fabrication	Signed-off cost; Cost reimbursable
Sandia National Lab	Detector fabrication	Signed-off cost; Direct-funded, cost plus fixed fee, capped
Omnisys	Spectrometer	Signed-off ROM; Cost plus fixed fee, capped
CalTech	Detector fabrication	Signed-off cost; Cost reimbursable
UCRYO	Cryostat	Signed-off cost; Cost plus fixed fee, capped
CryoMech	Refrigeration unit for cryostat	Signed-off cost; Cost plus fixed fee, capped
ASU	Science team (Groppi)	Signed-off cost; Cost reimbursable
SETI	Science team (Hollenbach)	Signed-off cost; Cost reimbursable
Colorado University	Science team (Bally)	Signed-off cost; Cost reimbursable
UCLA	Science team (Morris)	Signed-off cost; Cost reimbursable
Oberlin College	Science team (Martin)	Signed-off cost; Cost reimbursable
JHU	Science team (Neufeld)	Signed-off cost; Cost reimbursable
SAO	Science team (Melnick & Stark)	Signed-off cost; Cost reimbursable

or- organization. The costing methodology used by

each organization is summarized in the table below.

The UA project and instrument budgets were prepared using a grass-roots method with analogy to similar instruments such as the STO Balloon Flight instrument with adjustments for the OCAM requirements. The UA instrument budget incorporates the signed-off costs from all participating organizations as identified in the accompanying table. The UA project and instrument budgets utilize the certified forward pricing rates of the UA. The application of the rates to personnel and material costs has been reviewed and approved by the UA administration.

SRON, MIT, and CalTech prepared signed-off detector element estimates based on similar, previous efforts. Omnisys submitted signed-off costs based on the OCAM requirements and previous experience. Science team budgets were prepared based on the assigned roles and responsibilities for each activity.

G-1 UA Cost & Cost Estimating Methodology

The UA budget includes all OCAM costs including UA-specific costs, direct funded organizations, hard-

Participating Organizations		
Organization	Role	Basis of Estimate Funding
SRON (Netherlands)	Detector fabrication	Signed-off cost; Cost plus fixed fee, capped
MIT	Detector fabrication	Signed-off cost; Cost reimbursable
Sandia National Lab	Detector fabrication	Signed-off cost; Direct-funded, cost plus fixed fee, capped
Omnisys	Spectrometer	Signed-off ROM; Cost plus fixed fee, capped
CalTech	Detector fabrication	Signed-off cost; Cost reimbursable
UCRYO	Cryostat	Signed-off cost; Cost plus fixed fee, capped
CryoMech	Refrigeration unit for cryostat	Signed-off cost; Cost plus fixed fee, capped
ASU	Science team (Groppi)	Signed-off cost; Cost reimbursable
SETI	Science team (Hollenbach)	Signed-off cost; Cost reimbursable
Colorado University	Science team (Bally)	Signed-off cost; Cost reimbursable
UCLA	Science team (Morris)	Signed-off cost; Cost reimbursable
Oberlin College	Science team (Martin)	Signed-off cost; Cost reimbursable
JHU	Science team (Neufeld)	Signed-off cost; Cost reimbursable
SAO	Science team (Melnick & Stark)	Signed-off cost; Cost reimbursable

ware-providing subcontractors, and science team members. The UA-specific costs for the OCAM project organization and instrument was developed by grassroots and analogy to other missions, specifically the STO mission. A budget is developed by WBS (see Fig. H-1), fiscal year, and mission phase detailing the costs for personnel, equipment, travel, capital, and fabricated equipment. Personnel requirements are based on OCAM project plan and past experience of the STO project, taking into account the experience of the personnel assigned to the OCAM project, to establish the management, engineering, and technician funding requirements. Operations costs for personnel support are calculated from prorated actuals from other, similar programs. These costs costs for computer support and research supplies. Travel costs are estimated by counting the number of trips, traveling personnel and days for each destination by fiscal year by using current prices (for FY112 calculations to be escalated with NASA-approved inflation factors for real year dollars). Direct-funded and subcontracted organizations have prepared their own organizationally signed-off budgets. There is no UA overhead charge against dir-

Cost (Real Year Dollars)			
	Phase B	Phase C/D	Total
Cost	\$814 K	\$6,212 K	\$7,026 K
Reserve	\$204 K	\$1,553 K	\$1,757 K
NASA Totals	\$1,018 K	\$7,765 K	\$8,783 K
Contributed			
Reserve			
Total	\$1,018 K	\$7,765 K	\$8,783 K
Reserve %	25%	25%	25%

ect-funded costs; subcontracted costs include overhead charged against the first \$25K of each award. Capital fabricated equipment have been identified and priced. UA indirect costs apply to total personnel costs, operations costs, and fabricated equipment costs plus subcontracts as described above.

G-2 Cost Risk

Cost reserves were allocated as a function of uncertainty and risk. Cost uncertainty has two

primary sources: cost estimating uncertainty and cost growth due to unforeseen technical difficulties.

The cost reserve for OCAM (real year) is \$1.757M. This represents a conservative approach of 25% reserve for the entire project.

G-3 Small Business Participation

The OCAM team at the UA and its subcontractors have established a contracting plan to include small and disadvantaged businesses in its procurement activities, which is consistent with the overall NASA objective, FAR 52.219-9, and the laws of the State of Arizona. The Arizona Board of Regents has established a Master Subcontracting Plan that includes a Manager of the UA Small Business Supplier Diversity Program, Mr. Ernest Webster. Mr. Webster maintains qualified bidder lists of small, disadvantaged businesses These businesses are routinely included in appropriate solicitations. He also reviews all procurements from the UA for compliance with UA procurement practices relating to fairness in solicitations and awards.

The UA OCAM Team make solicitations through the UA Procurement Office for hardware and software services to small, disadvantaged business that will result in competitive awards. Candidate tasks for small disadvantaged businesses include machining and qualifying custom mechanical parts, performing test and verification for specialized activities, performing thermal analysis, performing structural analysis, participating in the overall instrument suite qualification process.

In Phase A, limited SB/SDB/WOSB subcontracting possibilities have been identified for thermal analysis consulting. OCAM will seek to achieve the goals of small/disadvantaged business contracting in Phase A by: (1) aggressively pursuing project opportunities and (2) purchasing goods and services using UA institutional subcontracts with SBs/SDBs/WOSBs (e.g., office supplies and temporary technical support).

FIGURE H-1: WBS AND WBS DICTIONARY

G-4 Basis of Estimate Details
Detailed budgets attached.

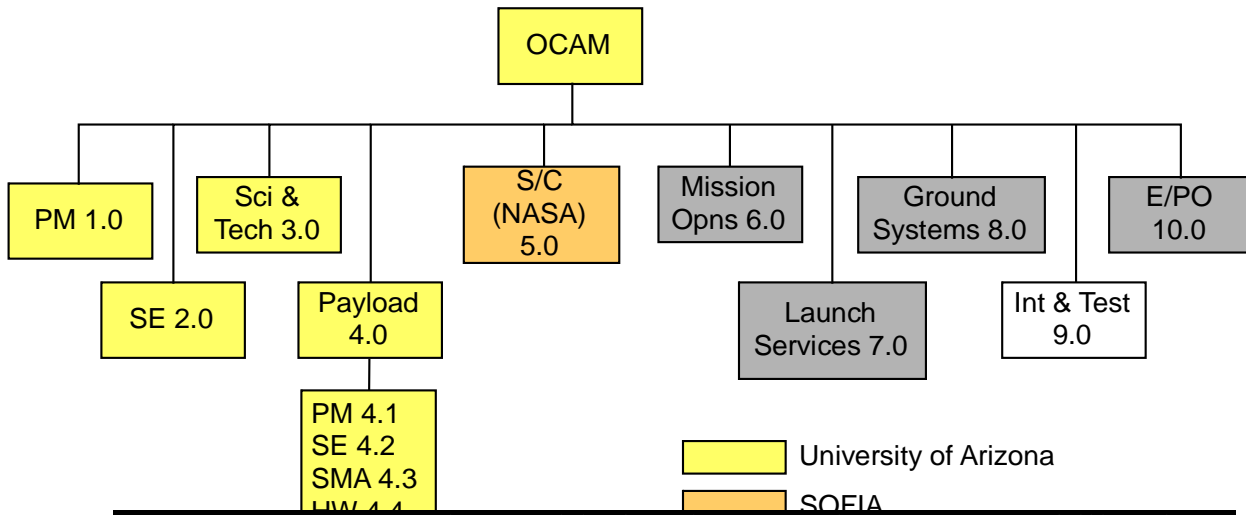

WBS	Title	Responsible Organization	Description of the equipment, data, services, human resources and facilities required to develop and produce integrated systems which meet Project level I requirements.
1.0	Project Management	UA (PI Org)	Element 1 - Project Management: The business and administrative planning, organizing, directing, coordinating, analyzing, controlling, and approval processes used to accomplish overall project objectives, which are not associated with specific hardware or software elements. This element includes project reviews and documentation, non-project owned facilities, and project reserves. It excludes costs associated with technical planning and management and costs associated with delivering specific engineering, hardware and software products.
2.0	Systems Engineering	UA (PI Org)	Element 2 - Systems Engineering: The technical and management efforts of directing and controlling an integrated engineering effort for the project. This element includes the efforts to define the project space flight vehicle(s) and ground system, conducting trade studies, the integrated planning and control of the technical program efforts of design engineering, software engineering, specialty engineering, system architecture development and integrated test planning, system requirements writing, configuration control, technical oversight, control and monitoring of the technical program, and risk management activities. Documentation products include requirements documents, interface control documents (ICDs), Risk Management Plan, and master verification and validation (V&V) plan. Excludes any design engineering costs.
3.0	Safety & Mission Assurance	UA (PI Org)	Element 3 - Safety and Mission Assurance: The technical and management efforts of directing and controlling the safety and mission assurance elements of the project. This element includes design, development, review, and verification of practices and procedures and mission success criteria intended to assure that the delivered Aircraft, ground systems, mission operations, and payload(s) meet performance requirements and function for their intended lifetimes. This element excludes mission and product assurance efforts directed at partners and subcontractors other than a review/oversight function, and the direct costs of environmental testing.

4.0	Science	UA (PI Org)	Element 4 - Science / Technology: This element includes the managing, directing, and controlling of the science investigation aspects, as well as leading, managing, and performing the technology demonstration elements of the Project. The costs incurred to cover the Principal Investigator, Project Scientist, science team members, and equivalent personnel for technology demonstrations are included. Specific responsibilities include defining the science or demonstration requirements; ensuring the integration of these requirements with the payloads, Aircraft, ground systems, and mission operations; providing the algorithms for data processing and analyses; and performing data analysis and archiving. This element excludes hardware and software for onboard science investigative instruments/payloads.
5.0	Project instrument (Payload)	UA (PI Org)	Element 5 - Payload: This element includes the equipment provided for special purposes in addition to the normal equipment (i.e., GSE) integral to the Aircraft. This includes leading, managing, and implementing the hardware and software payloads that perform the scientific experimental and data gathering functions placed on board the Aircraft, as well as the technology demonstration for the mission.
6.0	Flight System (SOFIA Platform)	NASA	Element 6 - Aircraft: The Aircraft that serves as the platform for carrying payload(s), instrument(s) and other mission-oriented equipment in space to the mission destination(s) to achieve the mission objectives. The Aircraft may be a single Aircraft or multiple Aircraft/modules (i.e., cruise stage, orbiter, Lander, or rover modules). Each Aircraft/module of the system includes the following subsystems, as appropriate: Power, Command & Data Handling, Telecommunications, Mechanical, thermal, Propulsion, Guidance Navigation and Control, Wiring Harness, and Flight software. This element also includes all design, development, production, assembly, test efforts, and associated GSE to deliver the completed system for integration with the launch vehicle and payload. This element does not include integration and test with payloads and other project systems.
7.0	Mission Operations	NA	Element 7 - Mission Operations System: The management of the development and implementation of personnel, procedures, documentation, and training required to conduct mission operations. This element includes tracking, commanding, receiving/processing telemetry, analyses of system status, trajectory analysis, orbit determination, maneuver analysis, target body orbit/ephemeris updates, and disposal of remaining end-of-mission resources. The same WBS structure is used for Phase E Mission Operation Systems but with inactive elements defined as "not applicable." However, different accounts must be used for Phase E due to NASA cost reporting requirements. This element does not include integration and test with the other project systems.
8.0	Launch Vehicle	NA	Element 8 - Launch Vehicle / Services: The management and implementation of activities required to place the Aircraft directly into its operational environment, or on a trajectory towards its intended target. This element includes launch vehicle, launch vehicle integration, launch operations, any other associated launch services (frequently includes an upper-stage propulsion system), and associated ground support equipment. This element does not include the integration and test with the other project systems.
9.0	Ground Systems Development	NA	Element 9 - Ground System(s): The complex of equipment, hardware, software, networks, and mission-unique facilities required to conduct mission operations of the Aircraft systems and payloads. This complex includes the computers, communications, operating systems, and networking equipment needed to interconnect and host the Mission Operations software. This element includes the design, development, implementation, integration, test, and the associated support equipment of the ground system, including the hardware and software needed for processing, archiving, and distributing telemetry and radiometric data and for commanding the Aircraft. Also includes the use and maintenance of the project testbeds and project-owned facilities. This element does not include integration and test with the other project systems and conducting mission operations.
10.0	Systems Integration & Testing	UA, UA & SOFIA	Element 10 - Systems Integration and Testing: This element includes the hardware, software, procedures, and project-owned facilities required to perform the integration and testing of the project's systems, payloads, Aircraft, launch vehicle/services, and mission operations.
11.0	Education & Public Outreach (EPO)	NA	Element 11 - Education and Public Outreach: Provide for the education and public outreach (EPO) responsibilities of NASA's missions, projects, and programs in alignment with the Strategic Plan for Education. Includes management and coordinated activities, formal education, informal education, public outreach, media support, and website development.