

ASTR 202 – Life in the Universe

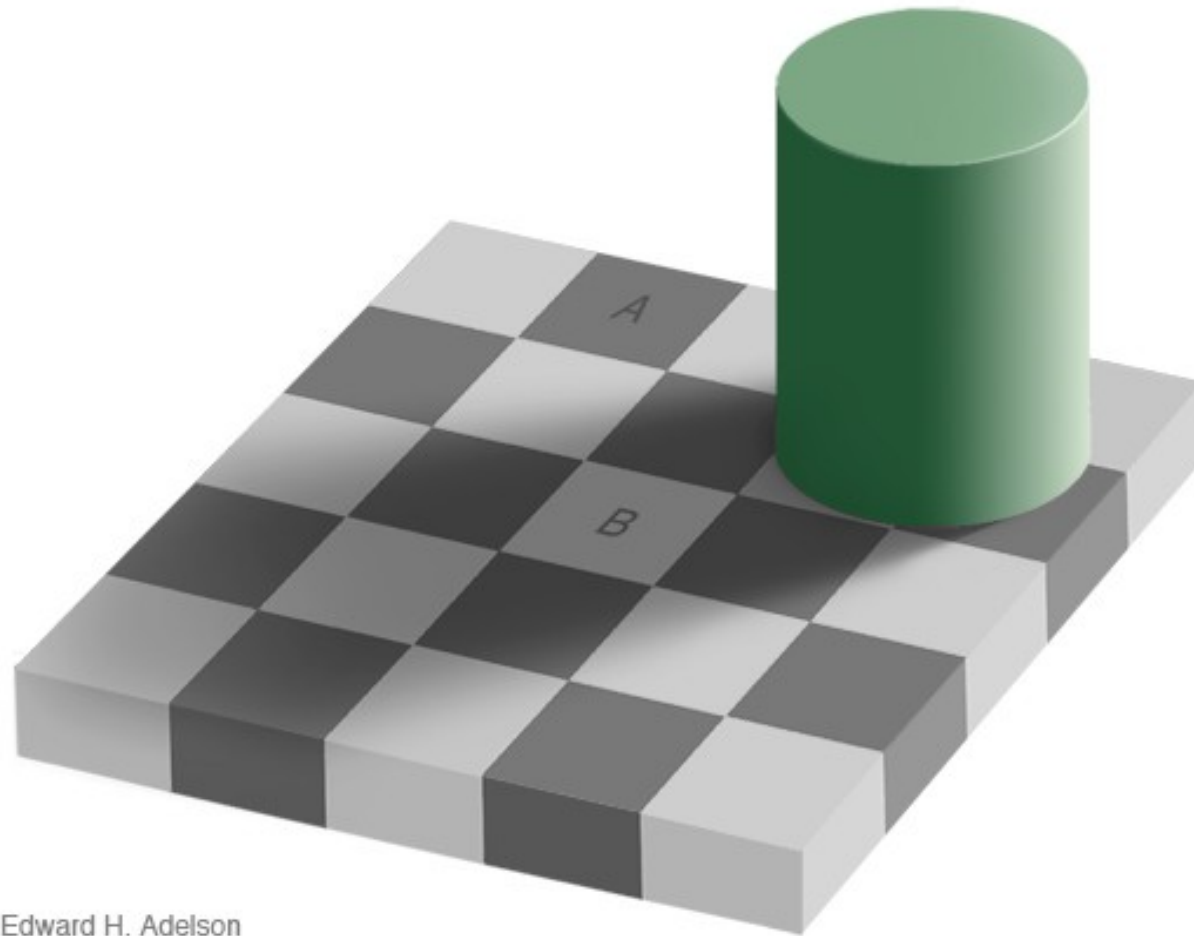

Edward H. Adelson

Brain bender of the day:
Which block is brighter, A or B?

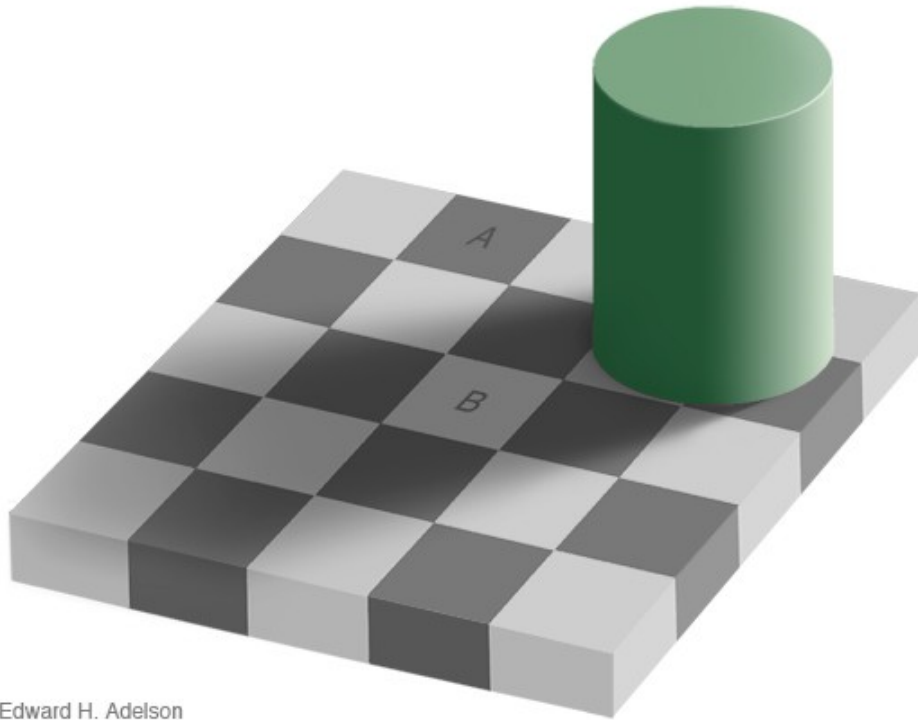

Edward H. Adelson

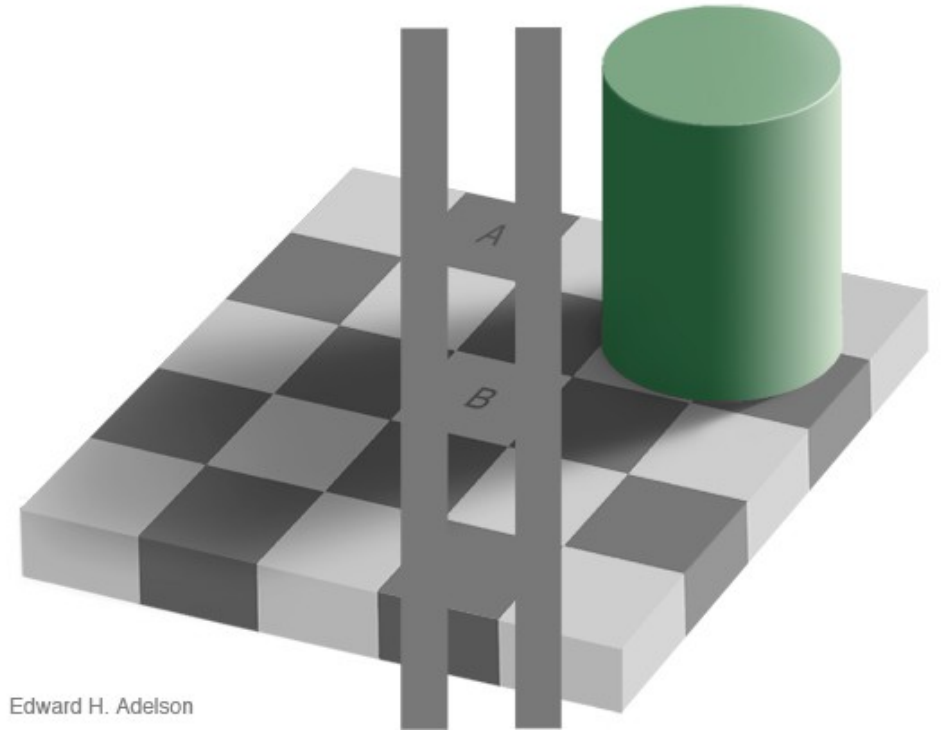

Edward H. Adelson

This is one reason that astronomers don't look through telescopes with their eyes; we use sensitive electronic 'eyes' that respond to light in a much more straightforward, linear fashion.

Here's another illusion...

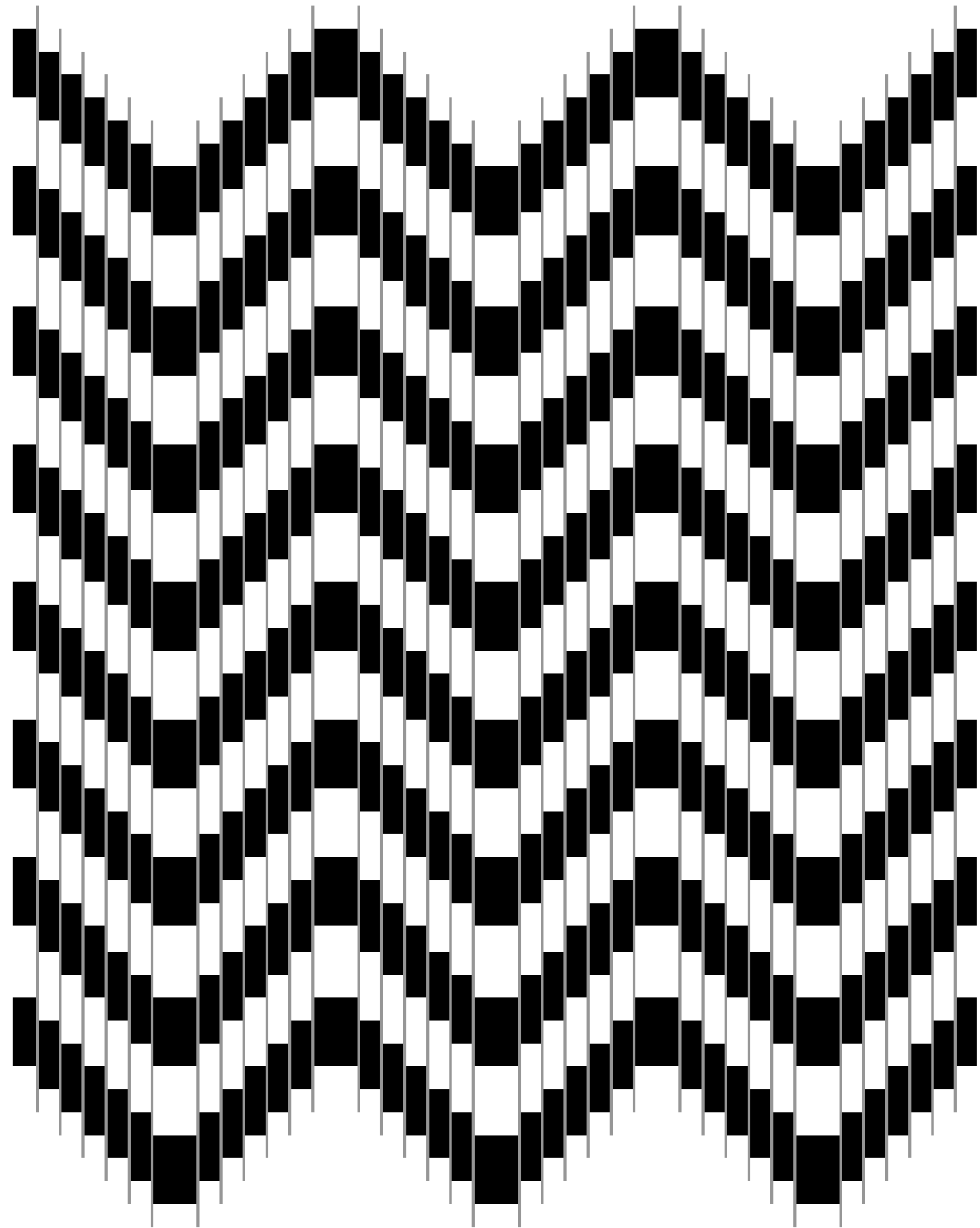

Similarly, in this lecture, we're also going to stretch your imagination a little bit!

ASTR 202 – Life in the Universe

So... filling in this week:

Dr. Craig Kulesa

Office: S.O. 222

(right across from Dr. Walker)



These notes may be found at:

<http://loke.as.arizona.edu/~ckulesa/classes/astr202/>

The Evolution of our Concept of the Universe

If we are to communicate with other civilizations in the Galaxy, then they must believe that **we** exist too.

What developments led to this realization?

- An understanding of the size and nature of the Universe
- A realization of their place in the Universe
- A belief that the detection and communication with other lifeforms is possible.

Historically, let's look at the developments that led to our current 'world' view...

- 3800 B.C. Babylonians create accurate astronomical calendar to guide crop planting and harvesting
- 3000 B.C. Babylonians develop 'oyster' model
- 1500 B.C. Egyptian water clocks, Stonehenge
- 400 B.C. Greece; Democritus conceptualizes the atom
- 350 B.C. Plato and Aristotle develop the geocentric model, with a spherical Earth; universe is controlled by cause and effect, not beings
- 230 B.C. Aristarchus develops a heliocentric model
- 200 A.D. Ptolemy elaborates the geocentric model, adding epicycles; it could explain almost every observation available at the time
- 420 A.D. St. Augustine labels “the itch to experiment and find out” a temptation to be avoided. And it was... for about 1000 years!
- 1200's A.D. St. Thomas reintroduces Aristotle, makes science somewhat 'okay'. But not at all completely – just ask Giordano Bruno (in 1600 he was burned at the stake for believing that the stars were other Suns, possibly with planets and inhabitants).

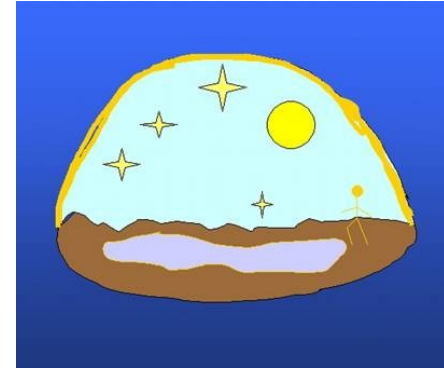

- 1540's: Copernicus re-develops the heliocentric model, but still with perfect circles and uniform motion. It didn't really work any better than Ptolemy's model.
- 1600's: Tycho Brahe (super accurate observations of planetary motions)
 - Kepler (planets in elliptical orbits move w/ varying speed)
 - Galileo (telescope – moons of Jupiter, sunspots, phases of Venus)
- 1687: Newton produces an analytical treatment of gravity and motion, “Principia” and “Mathematical Principles of Natural Philosophy”
- 1800's: Maxwell develops modern electromagnetic theory
- Early 1900's: Einstein (relativity); Planck, Schroedinger, and Bohr develop the modern treatment of the atom: quantum mechanics
- 1920's: Hubble & Humason discover that the Universe is expanding
- 1930's: development of radio astronomy (Grote Reber, Karl Jansky)
- 1960's: Drake, etc... advance the concept of SETI, first attempts to communicate

- So it took us about 10,000 years to go from hunter-gathering to a species capable of communicating between the stars. What about other worlds?
- Our example suggests that going from civilization to a communicable species is quite short! This suggests that $f_c = 1$.



Message sent from Arecibo radio telescope in 1974 toward globular cluster M13 (25,000 l.y. away)

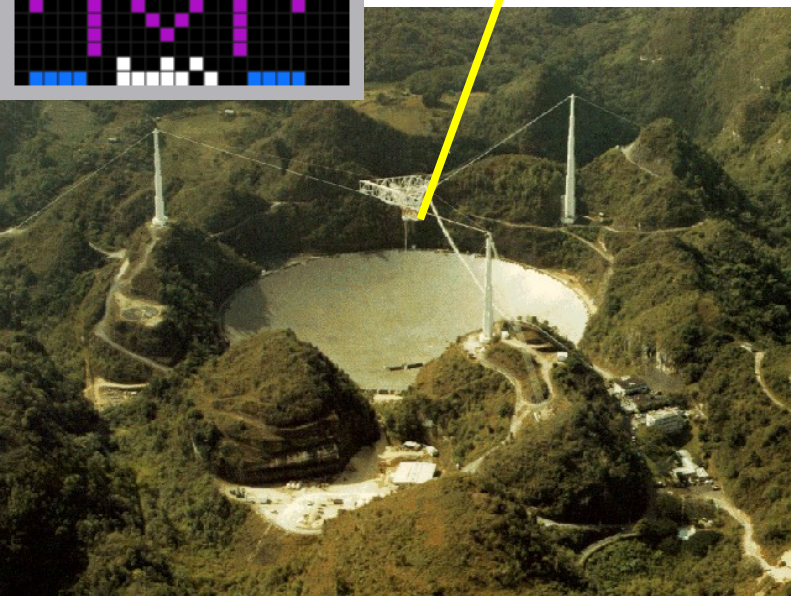

Rosetta Stone (discovered 1799)

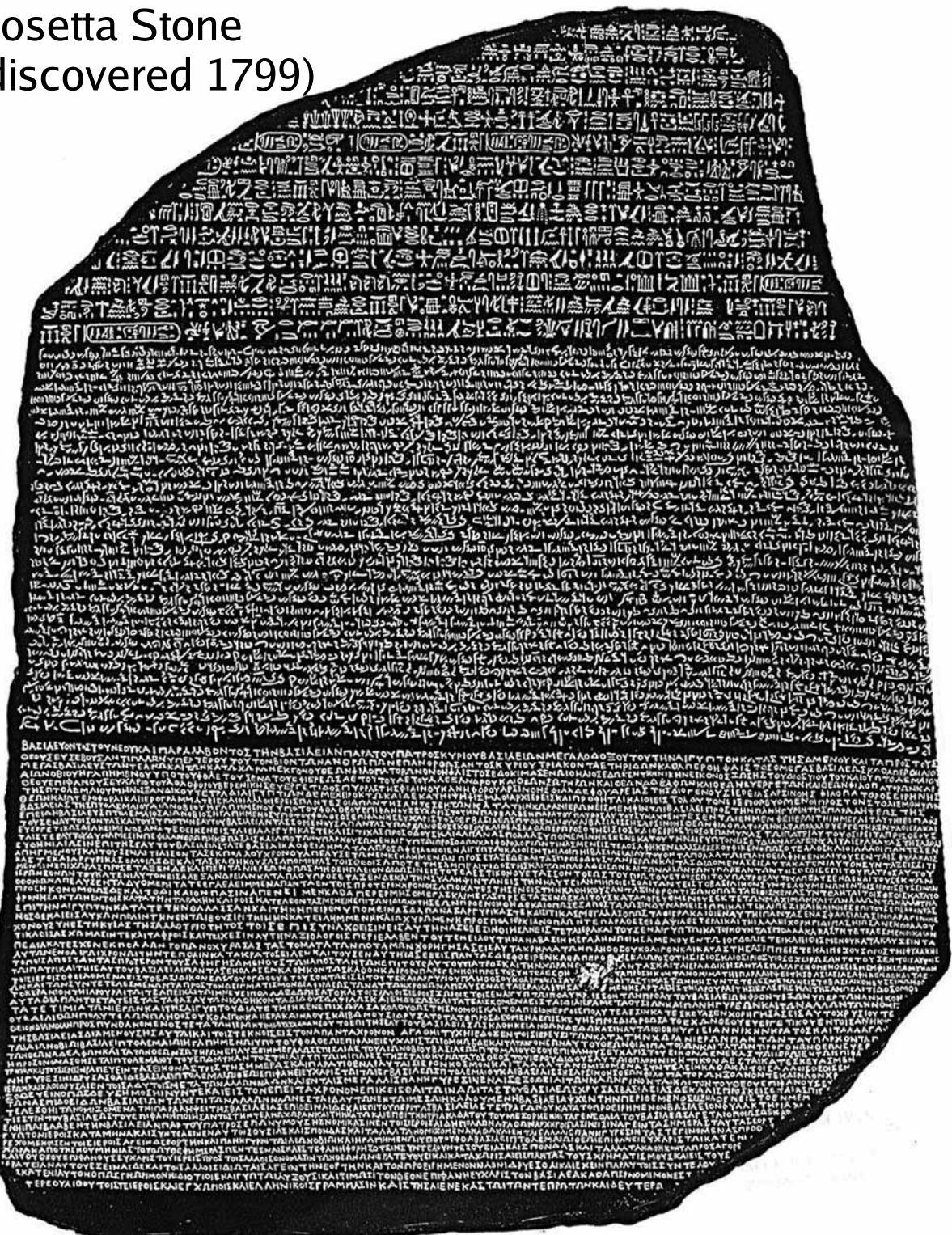

We are learning which nearby stars have planets. In fact, **these are the first planets directly imaged around a nearby star!** (a discovery announced only 2 weeks ago)

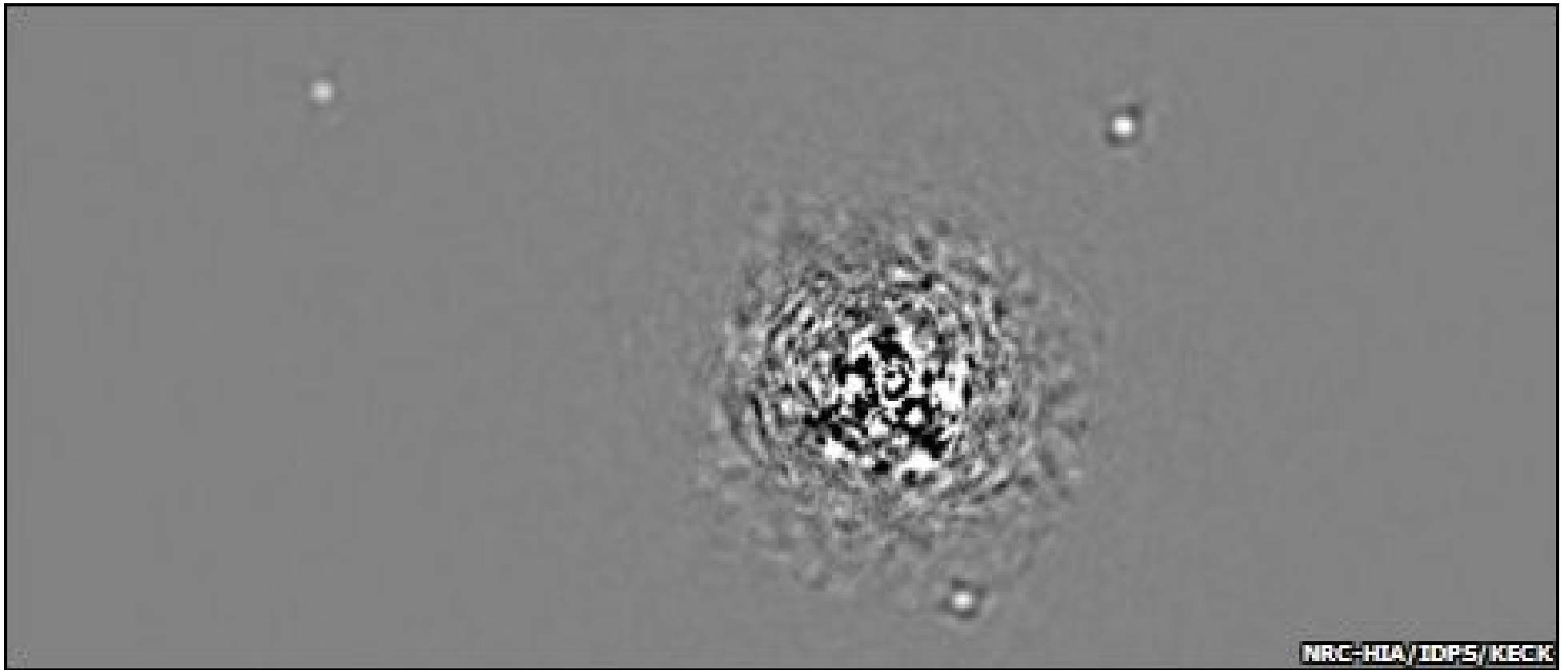

We are learning where might be the best places to aim our radio transmissions. But wouldn't it be even better to **go there?**

Interstellar Travel

Part 1



Why bother with interstellar travel?

- Radio SETI might fail
 - No civilizations close enough?
 - Wrong search frequency?
 - No beacons?
 - A “prime directive”? “zoo hypothesis”
- We want to study life on other planets
- Ensuring our own survival
- To explore is basic human instinct

Average distance to the nearest civilization, based on the number of civilizations you get from Drake's equation...

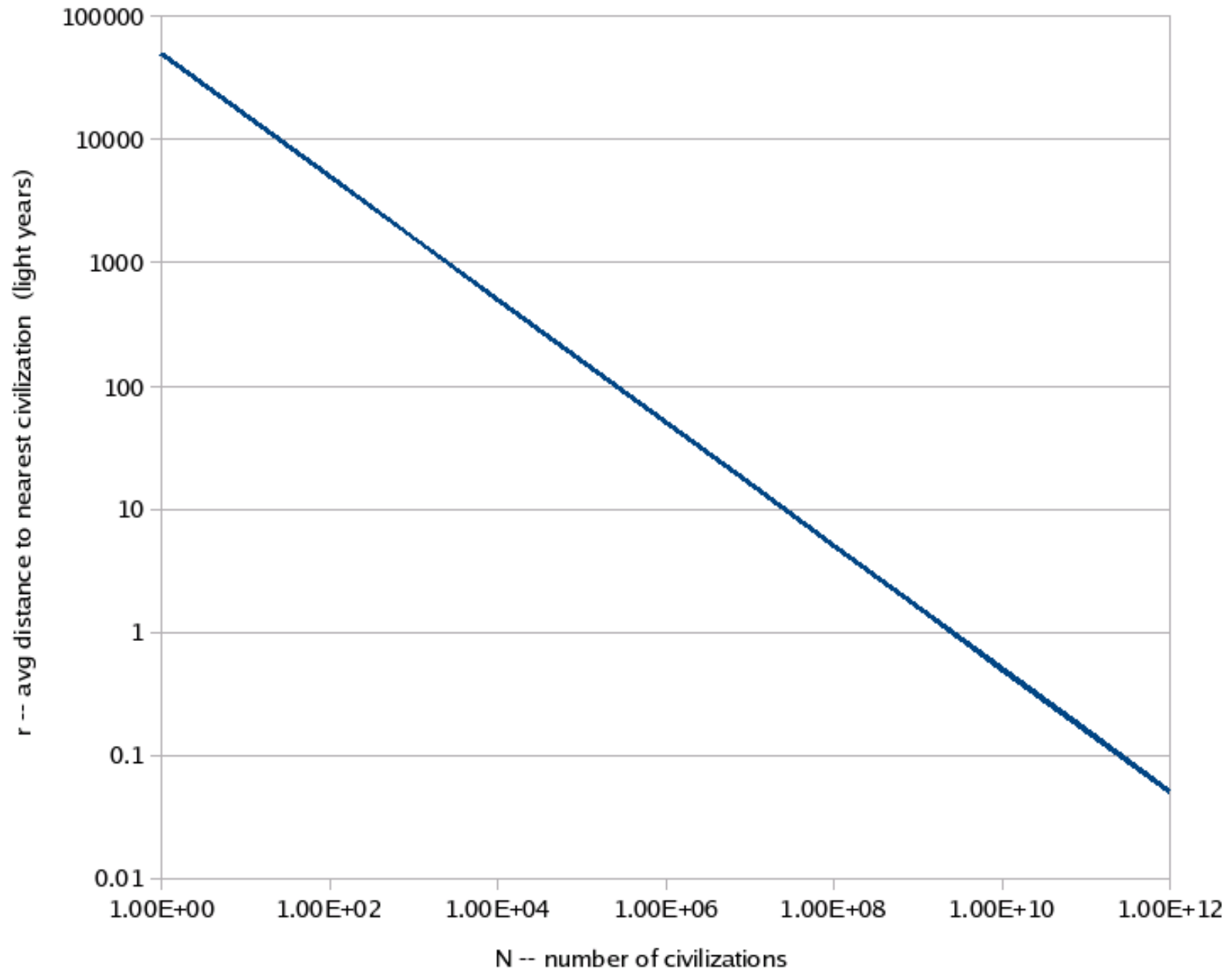

Most life in the Universe will be primitive

$$N_l = R \times f_p \times n_e \times f_l \times L$$

pessimist says $N_l \sim 2 \times 10^6$ (dist ~ 100 ly)

middle of road says $N_l \sim 7 \times 10^9$ (~ 5 ly)

optimist says $N_l \sim 10^{11}$ (they're everywhere)

How might we explore the stars?

Simpler question: How did we explore the moon?

- Astronomical observations
- First fly-bys
- Unmanned landings
- Manned missions w/o landings
- Manned landings – brief visits
- colonization

Time and Energy Requirements



Voyager 1 was launched in 1977, visited all four Jovian planets, and is now on its way out of the Solar System.

Example: Voyager 1
(fastest interstellar
spacecraft)

$$v = 15 \text{ km/s, or } 4 \times 10^{-5} c$$

It would take:

$$\begin{aligned} t = D / v &= 4 \text{ ly} / 4 \times 10^{-5} c \\ &= 100,000 \text{ years to} \\ &\text{reach the nearest} \\ &\text{star!} \end{aligned}$$

So chemical rocket engines
just won't cut it.

Project Orion

Conceived in the 1950's, this design explodes **fission bombs** 30 meters behind the spacecraft to propel it to higher speeds. In 10 days, you could be going $0.03c$!

So...

Nearest stars
in ~ 130 years

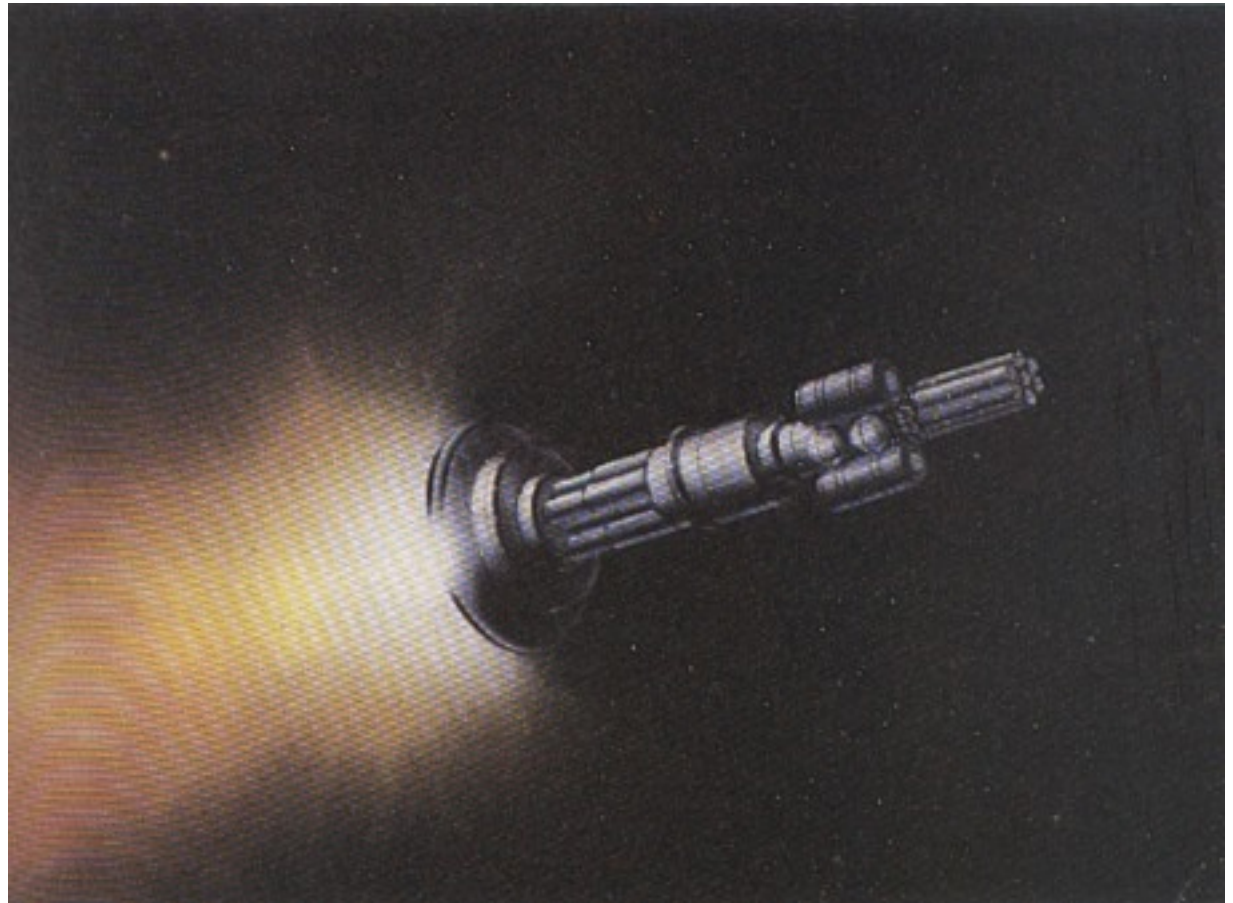

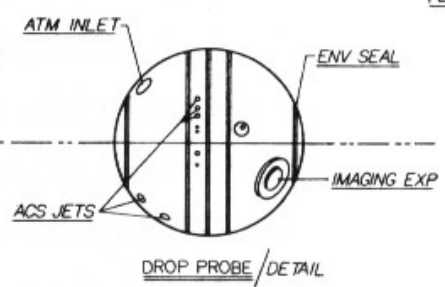
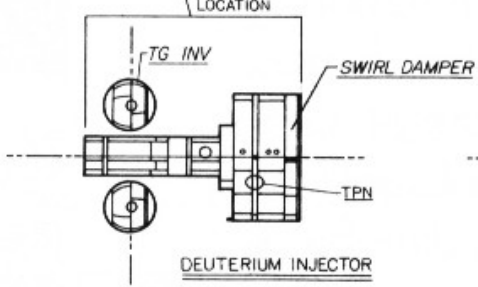
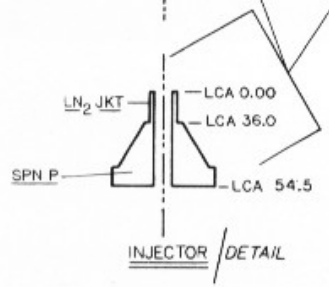
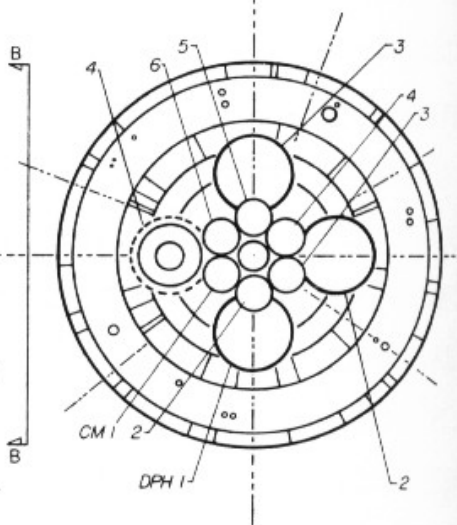
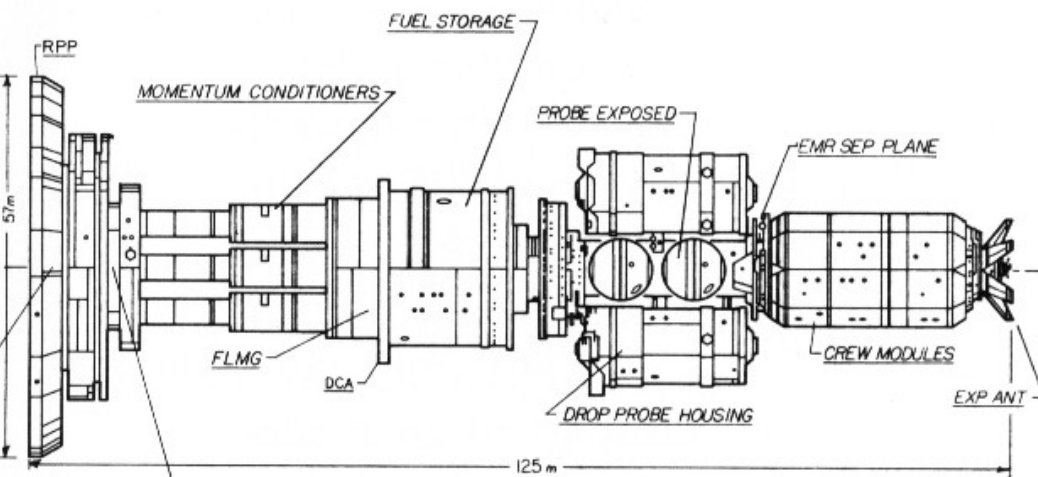
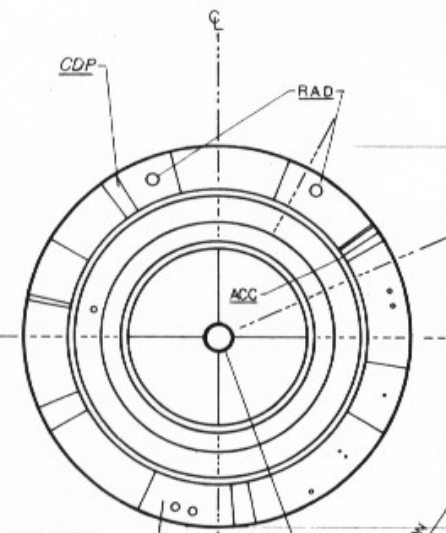
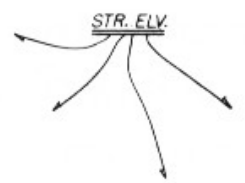
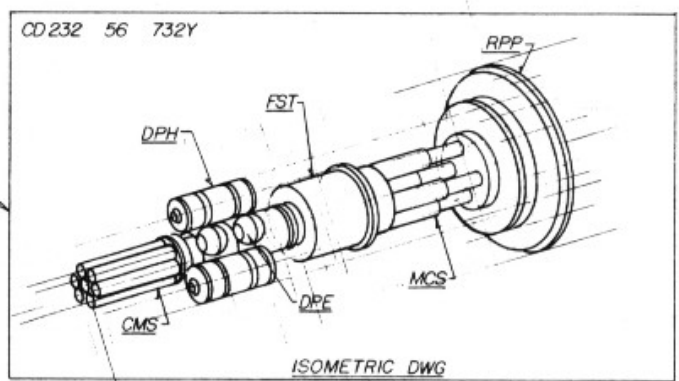
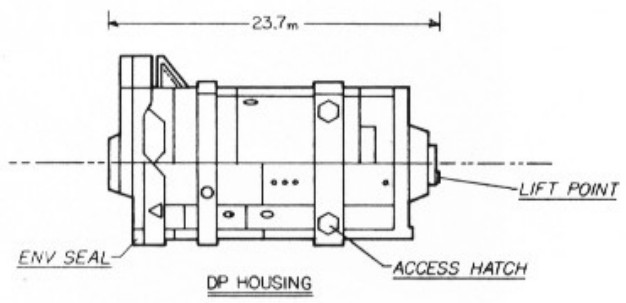

ORION NUCLEAR STARSHIP T2			
SCALE: NOTED	APPROVED BY: ENGINEERING	DATE: 2-3-95	REVISION: 1
GENERAL LAYOUT / SPACECRAFT			
DRAWING NUMBER: P379 S			REVISION: 1

Project Daedalus

- 1970's design that replaces the fission bomb acceleration device with a nuclear fusion drive system

$V = 0.12 c$

(50 years to reach nearest stars)

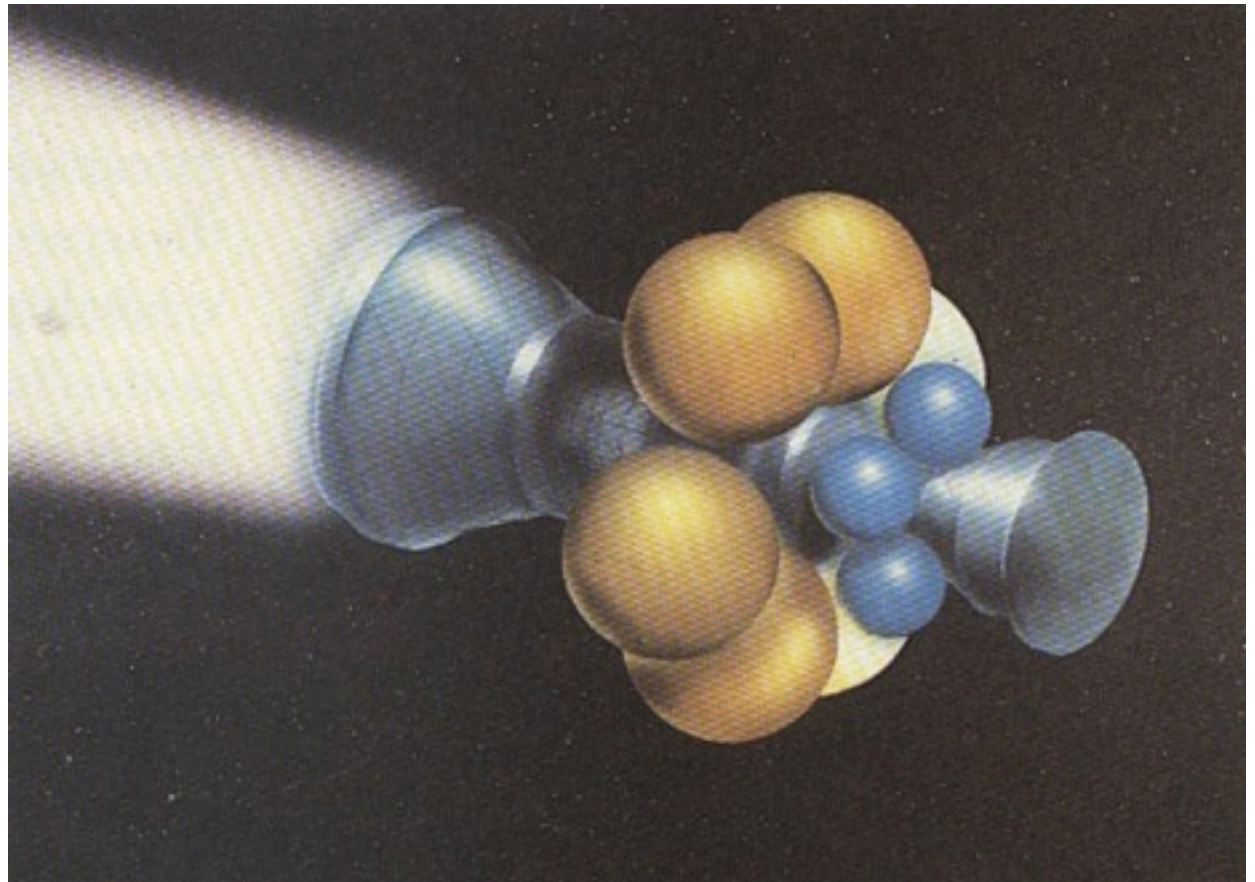

Advantages of fusion

- Fission only converts $\sim 1.2 \times 10^{-3}$ % of the fuel mass to energy: specific impulse = 1.5×10^6 sec (chemical rockets have s.i. = 500 sec)

specific impulse = “thrust per unit mass of fuel”

- Fusion converts 10x more matter into usable energy. Best fuel would be a combination of heavy hydrogen and light helium:

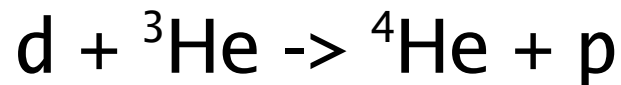

By-products would be **charged particles**, so a big magnetic field could steer them away from human occupants (and the ship)

What might a nuclear fusion drive system look like?

●C.D.F

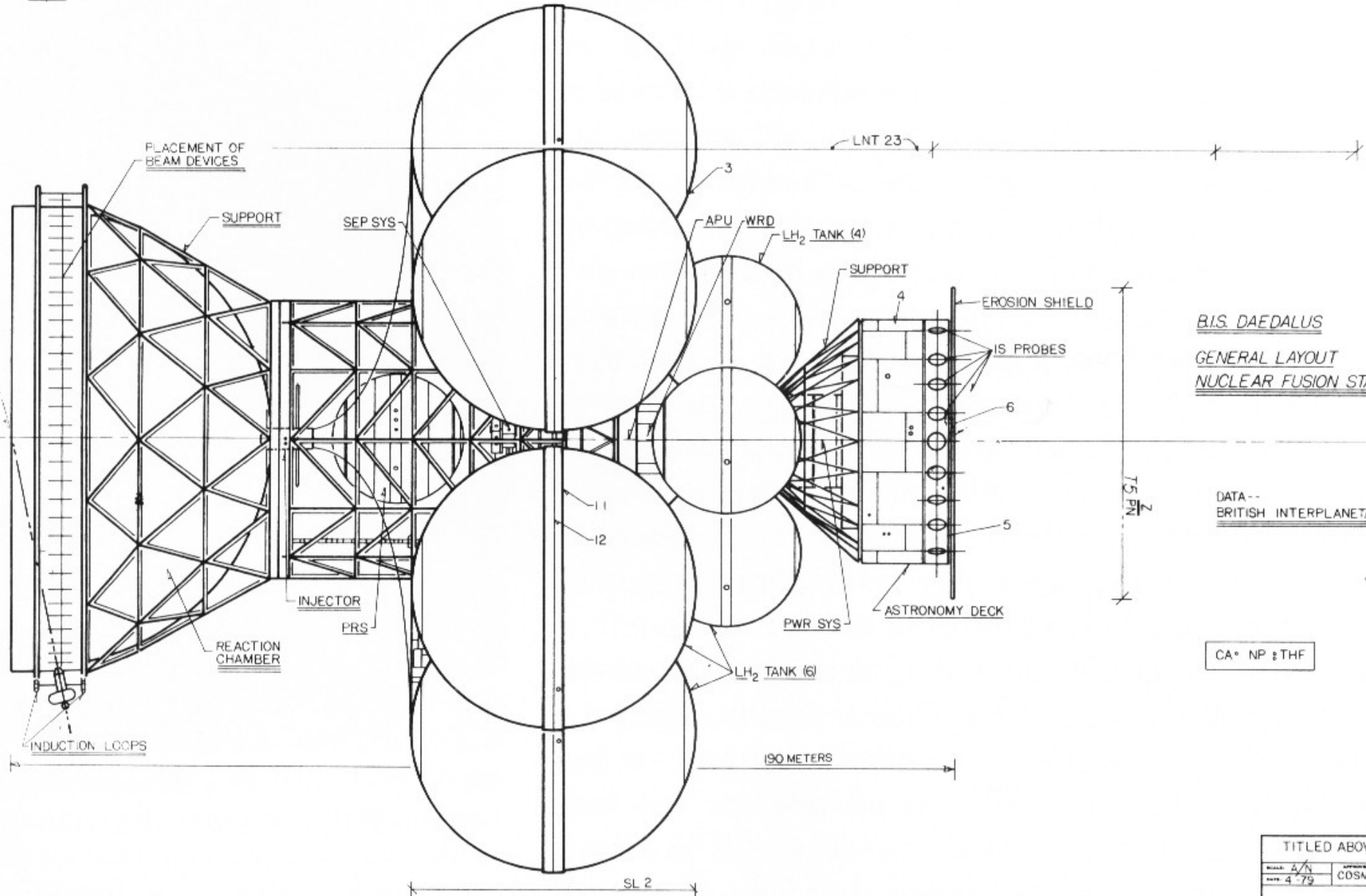

B.S. DAEDALUS
GENERAL LAYOUT
NUCLEAR FUSION STARSHIP

DATA --
BRITISH INTERPLANETARY SOCIETY

CA° NP : THF

TITLED ABOVE		
SCALE: 1/4" = 1'	APPROVED BY: COSMOS	DESIGNED BY: BHS
DATE: 4-79		REVISED:
		SCALE: 1 OF 1

Matter-antimatter drive (a la 'Star Trek')

- The Good: matter and anti-matter annihilate each other and give off gamma rays (light). All 'matter' is turned to energy. Efficient!
- The Bad: antimatter doesn't normally exist, and how do we contain it?

Bussard Ramjet

- Fusion drive system, with a **giant** scoop to collect interstellar matter as fuel

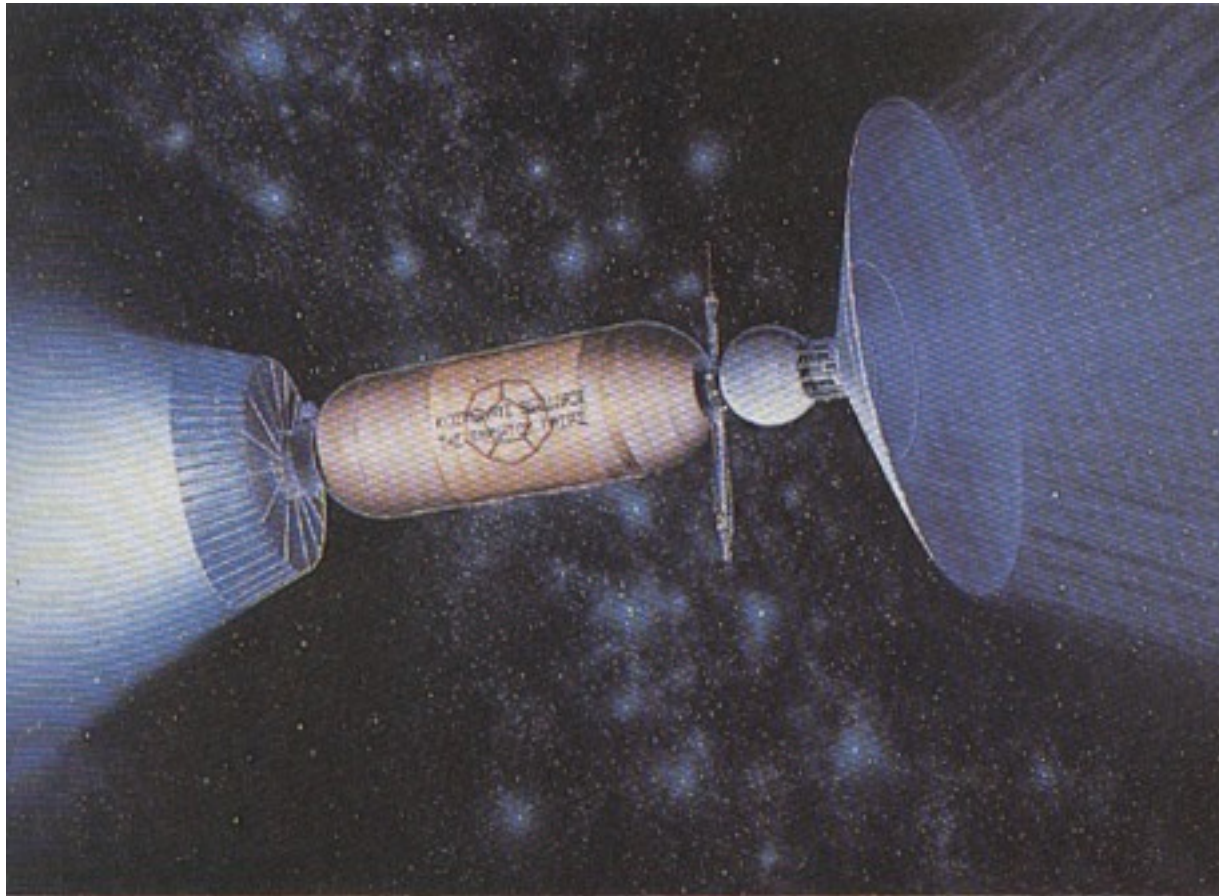

HYDROGEN SCOOP
2.3UV

NOTE: PERSPECTIVE VIEW ON DWG P4
17 DEG ELV
20 DEG ELLIP

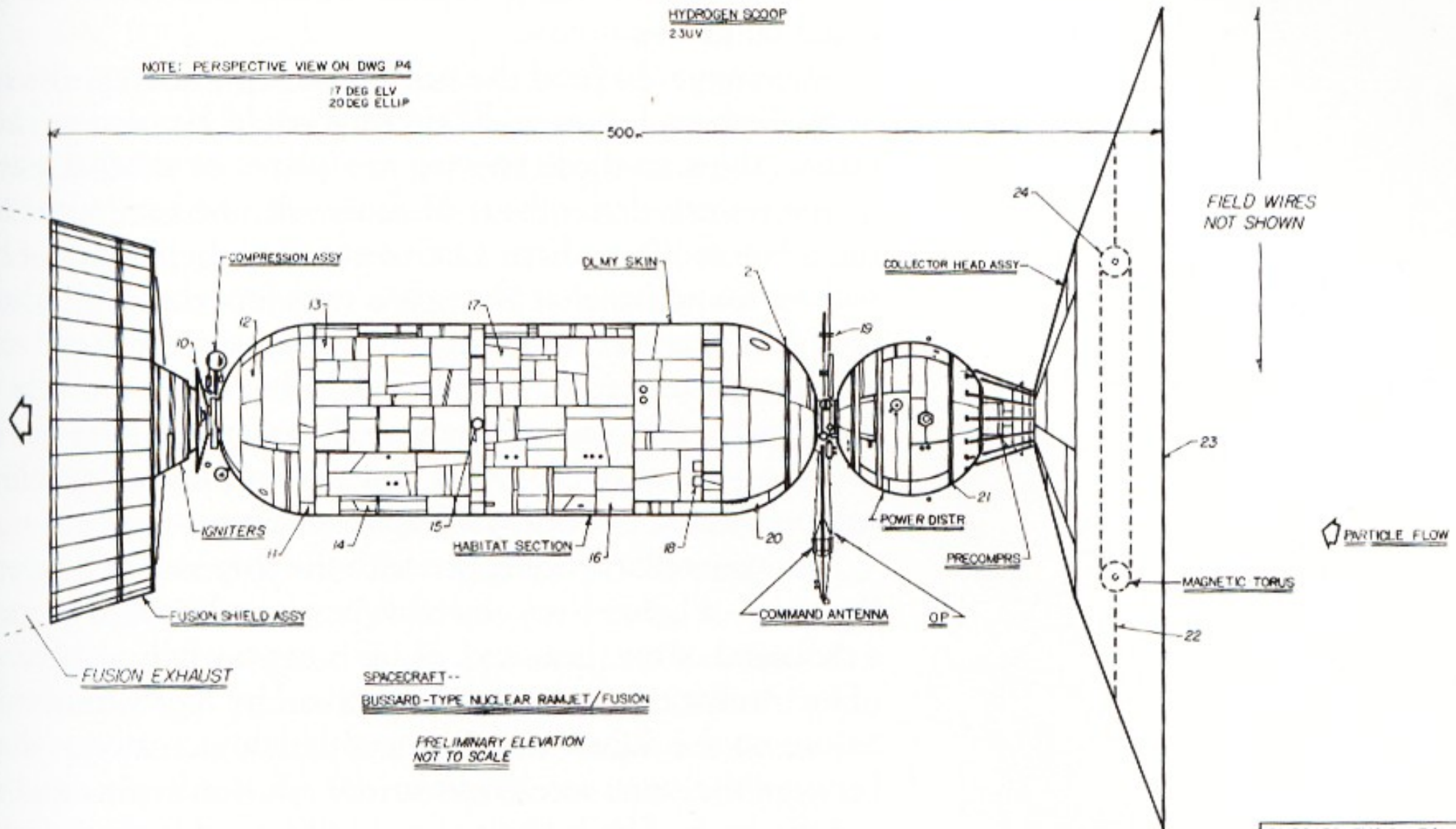

SPACECRAFT--
BUSSARD-TYPE NUCLEAR RAMJET/FUSION

PRELIMINARY ELEVATION
NOT TO SCALE

This is a spacecraft the size of a small planet!

BUSSARD FUSION RAMJET			
DATE: 2-3-99	DESIGN SECT.	DESIGNED BY: E.D.	APPROVED BY:
Rev. Gen. Layout			MN 37

Laser Propulsion

Beamed Propulsion Concepts

Laser Light Sail
1984...
R. Forward, et al

Star Warp
1985
R. Forward

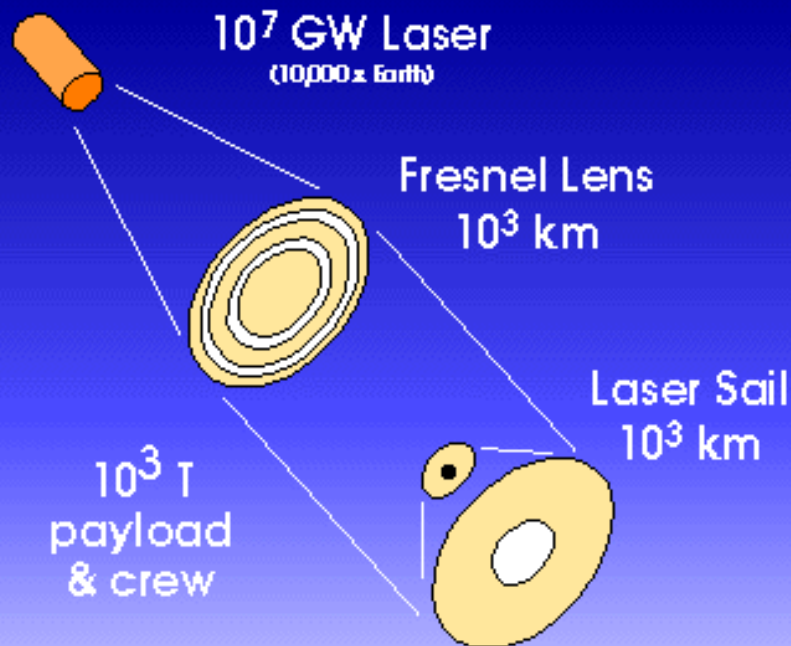

10 YEARS one way

20 YEARS one way

Implications of near-light speed: Time Dilation

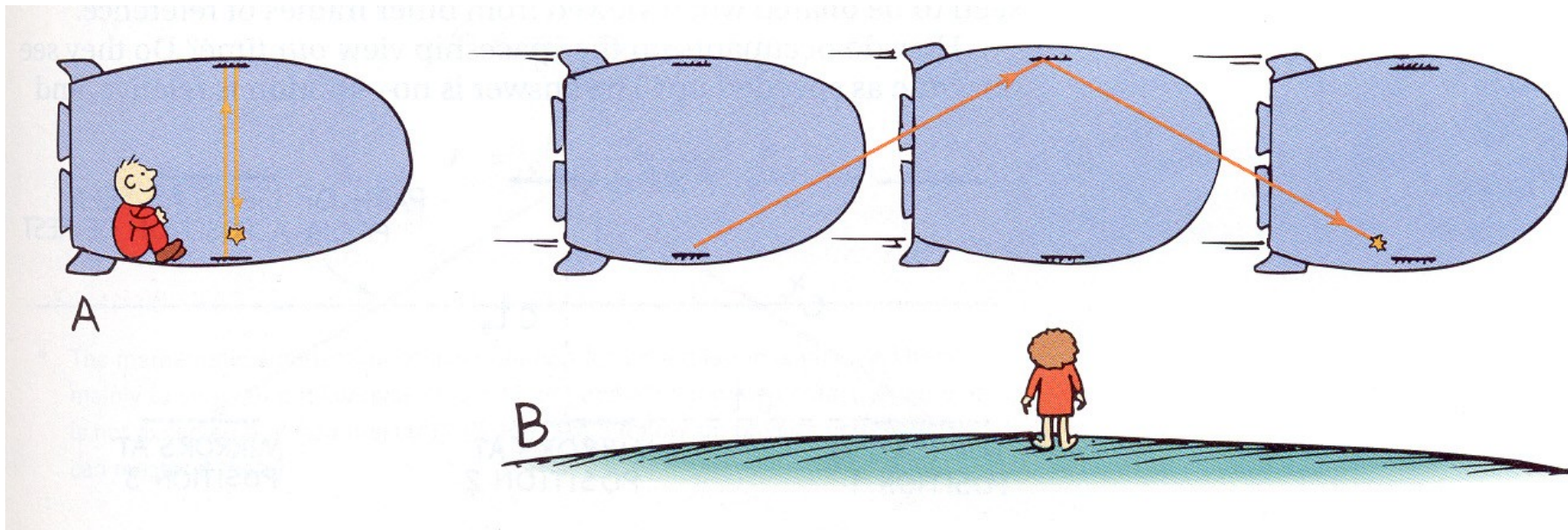

Moving clocks run slow!

Time Dilation Has Been Measured

All Global Positioning Systems use it!

- Airplane clocks run slower
 - Hafele & Keating (1972)
- Cosmic rays hit the atmosphere at high speed ($0.99c$)
 - Collisions make 'muons' which travel to Earth
 - Muons decay with a half-life = 1.5 microsec
 - Number of muons should depend on altitude
 - At 6000 ft, expect 570 muons/hr
 - At sea level, expect 35
 - Observe 400 muon/hour at sea level
- For the speedy muon, the decay rate is 9x longer!

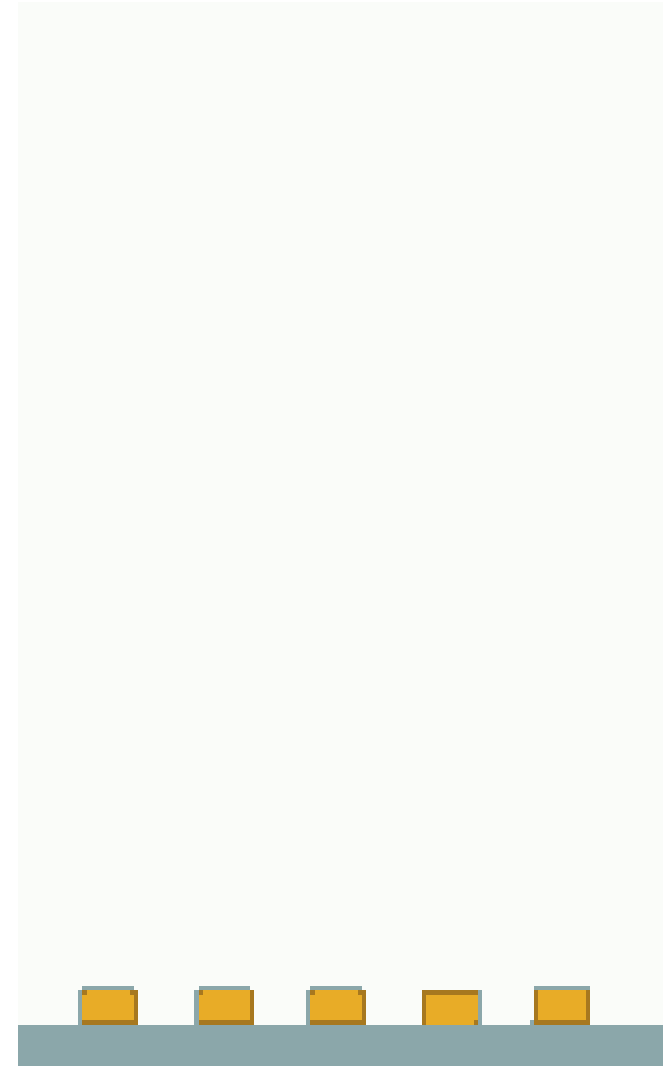

this is an animated .gif movie

Perspectives

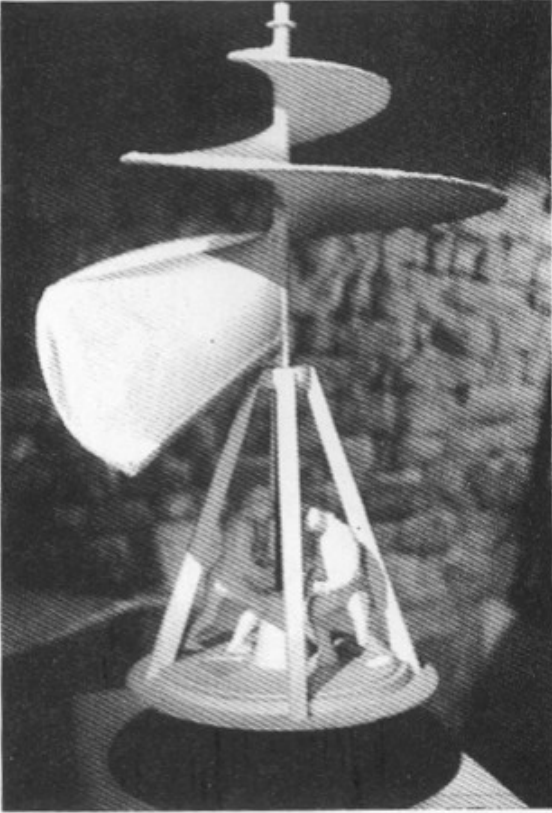

- We are probably no closer to the actual interstellar spacecraft of the future, than Da Vinci was in getting the first helicopter or airplane right.
- Still, this is the necessary first step. Early airplane designers built from knowledge of Da Vinci's work.

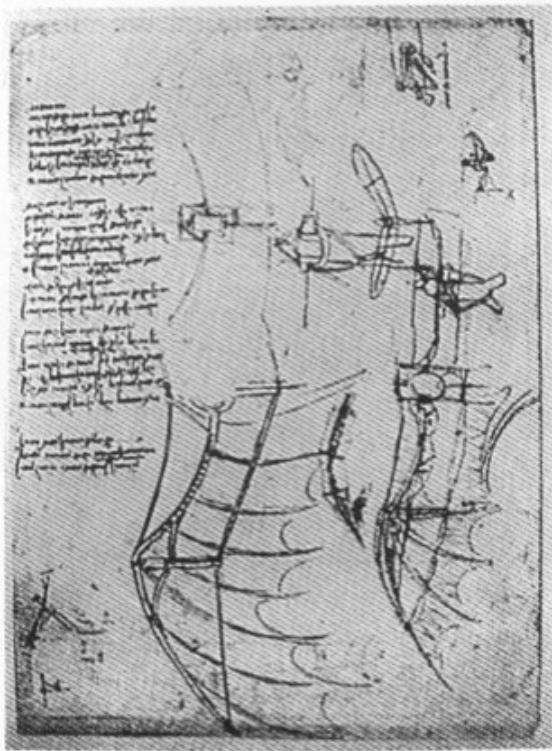

These notes may be found at:

<http://loke.as.arizona.edu/~ckulesa/classes/astr202/>